

## 05360400 - LT-S D60 ER32F OF105 LR HRF H93

<b>Type</b>	LT-S OFS Tool holder straight offset
<b>Mounting</b>	CYLINDRICAL SHANK 60
<b>Tool output</b>	Collet nut ER 32 F - internal nut
<b>Coolant</b>	HRF Internal coolant
<b>Offset [mm]</b>	105
<b>Direction of rotation</b>	r1  r2
<b>Max speed [rpm]</b>	6000
<b>Max torque [Nm]</b>	63
<b>Ratio</b>	1:1
<b>H [mm]</b>	93
<b>Max pressure [bar]</b>	80
<b>Accessories</b>	N.A.
<b>Notes</b>	N.A.
<b>Mounting tips</b>	Right star-type turret

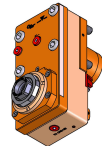

Always check live tool dimensions on the turret

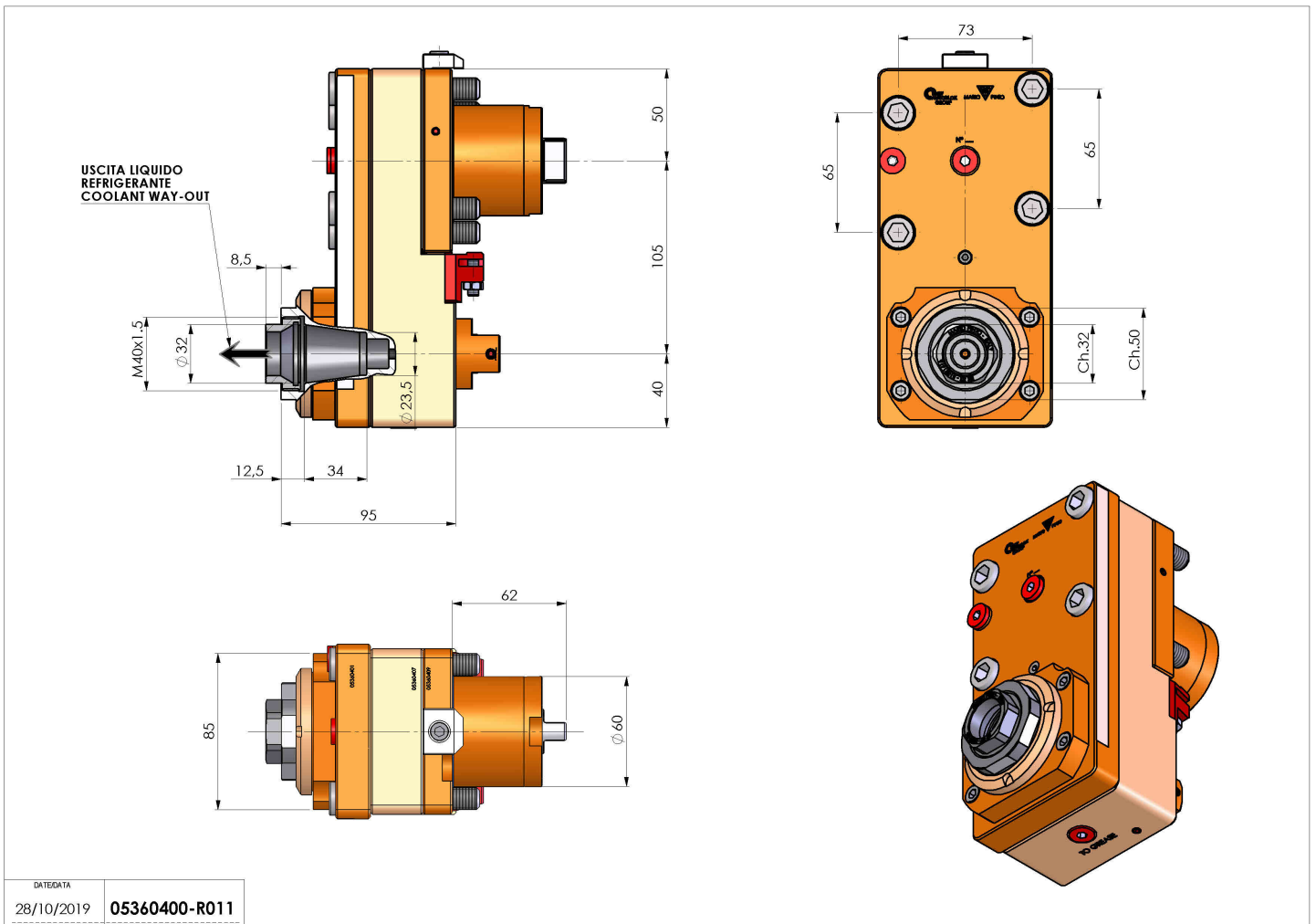

DATE/DATE	28/10/2019
PART NUMBER	05360400-R011

Subject to technical changes