

# 05358300 - LT-A VDI40 ER25 1:2 ADJ H130

Type	LT-A Tool holder angle 90°
Mounting	VDI 40
Tool output	Collet nut ER 25
Coolant	External coolant
Direction of rotation	r1 ↻ r2 ↻
Max speed [rpm]	5000
Max torque [Nm]	60
Ratio	1:2
H [mm]	130
H1 [mm]	32.5
Accessories	N.A.
Notes	N.A.
Mounting tips	N.A.

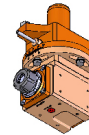

**ATTENTION: CHECK THE ORIENTATION OF THE VDI TEETH**

Always check live tool dimensions on the turret

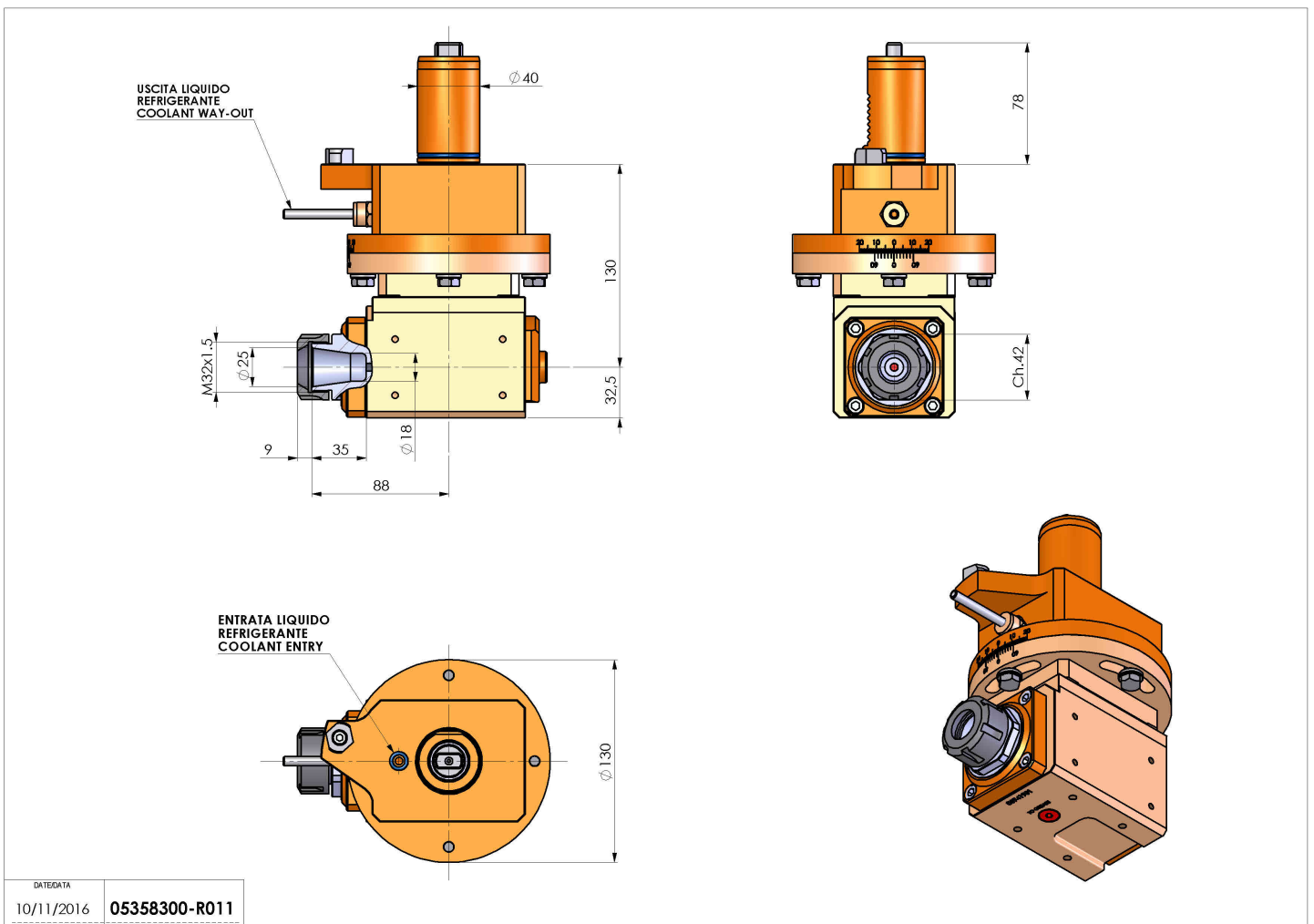

DATE/GATA	10/11/2016
	05358300-R011

Subject to technical changes