

# 05355900 - LT-A VDI40 ER25F R H67.5 MZ

|                       |                                   |
|-----------------------|-----------------------------------|
| Type                  | LT SPECIALE<br>Custom tool holder |
| Mounting              | VDI 40                            |
| Tool output           | Collet nut ER 25 F - internal nut |
| Coolant               | External coolant                  |
| Direction of rotation | r1 ↻ r2 ↻                         |
| Max speed [rpm]       | 6000                              |
| Max torque [Nm]       | 63                                |
| Ratio                 | 1:1                               |
| H [mm]                | 67,5                              |
| H1 [mm]               | 32,5                              |
| Accessories           | N.A.                              |
| Notes                 | N.A.                              |
| Mounting tips         | N.A.                              |

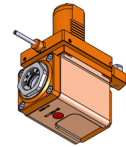

**ATTENTION: CHECK THE ORIENTATION OF THE VDI TEETH**

Always check live tool dimensions on the turret

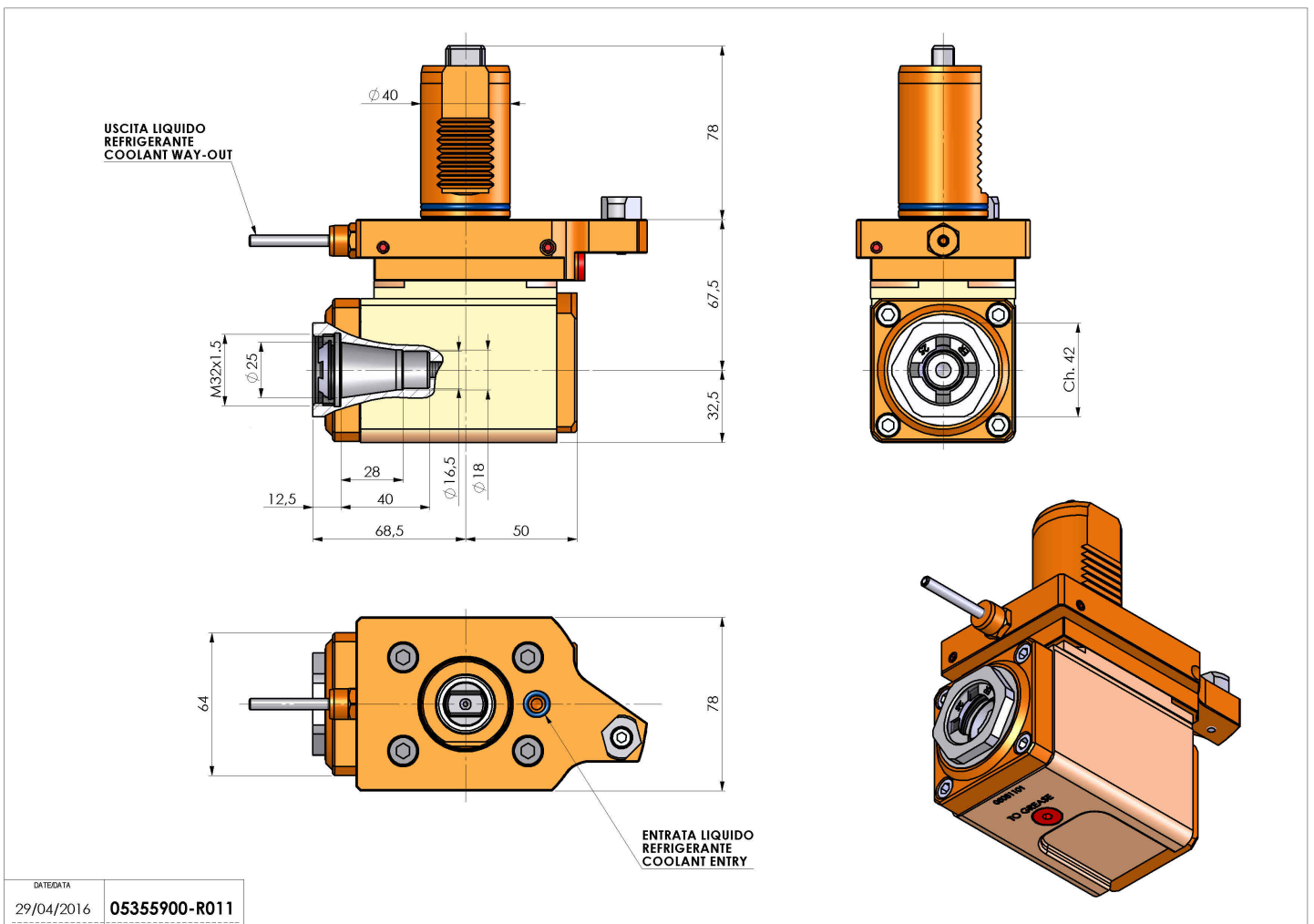

|            |               |
|------------|---------------|
| DATE/DATE  | 05355900-R011 |
| 29/04/2016 |               |

Subject to technical changes