

05355700 - LT-S2 VDI40 ER32F HRF H99 MZ

Type	LT SPECIALE Custom tool holder
Mounting	VDI 40
Tool output	Collet nut ER 32 F - internal nut
Coolant	HRF Internal coolant
Direction of rotation	r1 ↻ r2 ↻ r3 ↻
Max speed [rpm]	6000
Max torque [Nm]	63
Ratio	1:1
H [mm]	99
Max pressure [bar]	80
Accessories	N.A.
Notes	N.A.
Mounting tips	N.A.

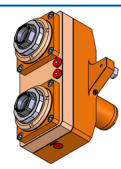

ATTENTION: CHECK THE ORIENTATION OF THE VDI TEETH

Always check live tool dimensions on the turret

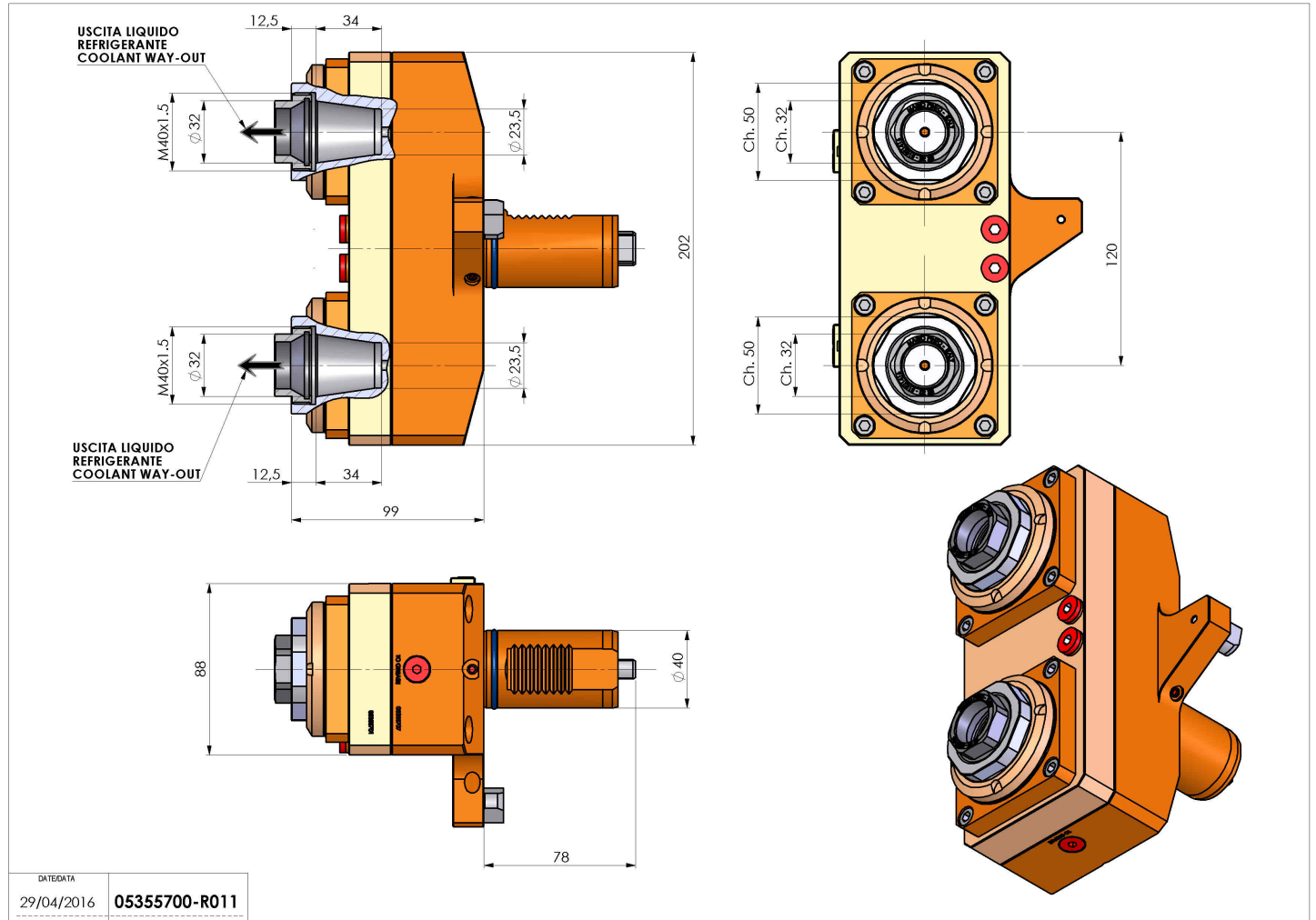

DATE/GATE
29/04/2016 05355700-R011

Subject to technical changes