

# 05354400 - LT-A VDI40 138-32 R 2:1 H100

|                              |                               |
|------------------------------|-------------------------------|
| <b>Type</b>                  | LT-A<br>Tool holder angle 90° |
| <b>Mounting</b>              | VDI 40                        |
| <b>Tool output</b>           | Shell-Mill DIN138 32          |
| <b>Coolant</b>               | External coolant              |
| <b>Direction of rotation</b> | r1 ↻ r2 ↻                     |
| <b>Max speed [rpm]</b>       | in 6000 / out 3000            |
| <b>Max torque [Nm]</b>       | in 70 / out 140               |
| <b>Ratio</b>                 | 2:1                           |
| <b>H [mm]</b>                | 100                           |
| <b>H1 [mm]</b>               | 43                            |
| <b>Accessories</b>           | N.A.                          |
| <b>Notes</b>                 | N.A.                          |
| <b>Mounting tips</b>         | Secondary spindle only        |

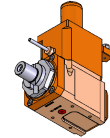

**ATTENTION: CHECK THE ORIENTATION OF THE VDI TEETH**

Always check live tool dimensions on the turret

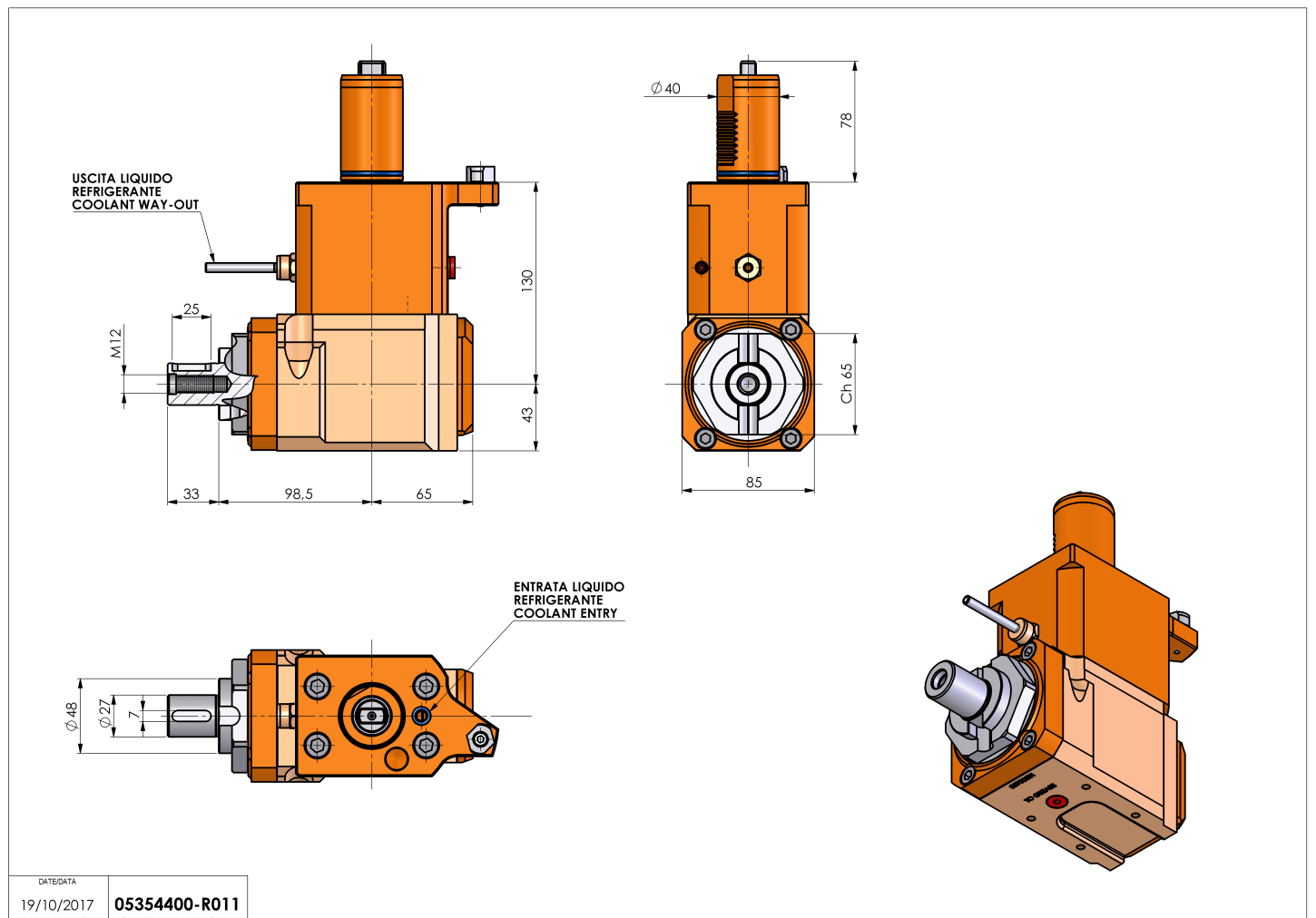

Subject to technical changes