

05353000 - LT-T D80 ER20F H64-144 MZ

Type	LT-T Tool holder tiltable
Mounting	CYLINDRICAL SHANK 80
Tool output	Collet nut ER 20 F - internal nut
Coolant	External coolant
Direction of rotation	r1 ↻ r2 ↻
Max speed [rpm]	6000
Max torque [Nm]	20
Ratio	1:1
H [mm]	63,5-143,5
Accessories	N.A.
Notes	N.A.
Mounting tips	N.A.

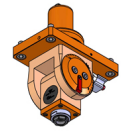

Always check live tool dimensions on the turret

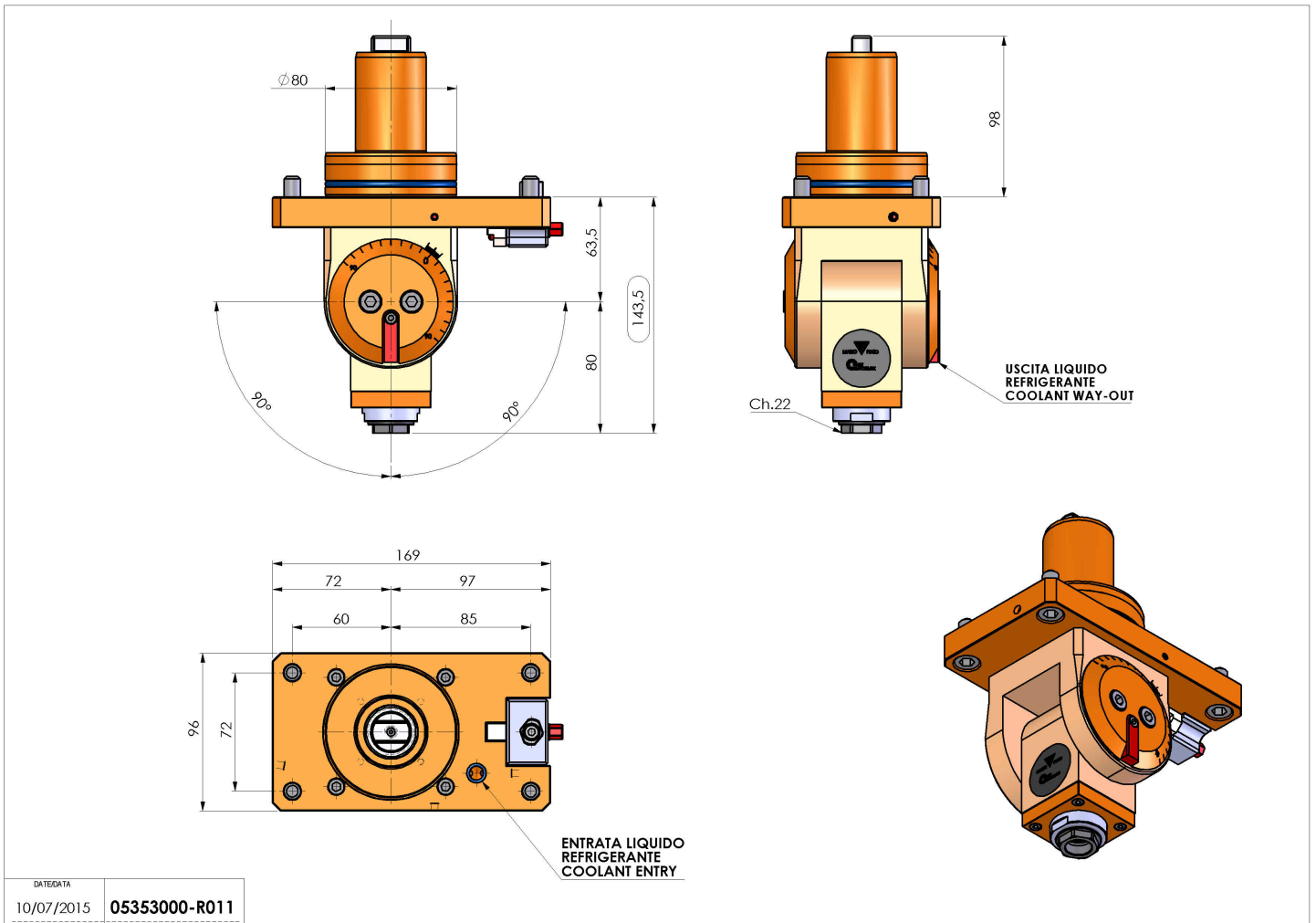

DATE/DATE	05353000-R011
10/07/2015	

Subject to technical changes