

05352200 - LT-A D80 ER40F H100 MZ

Type	LT-A Tool holder angle 90°
Mounting	CYLINDRICAL SHANK 80
Tool output	Collet nut ER 40 F - internal nut
Coolant	External coolant
Direction of rotation	r1 ↻ r2 ↻
Max speed [rpm]	6000
Max torque [Nm]	80
Ratio	1:1
H [mm]	100
H1 [mm]	43
Accessories	N.A.
Notes	N.A.
Mounting tips	N.A.

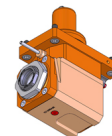

Always check live tool dimensions on the turret

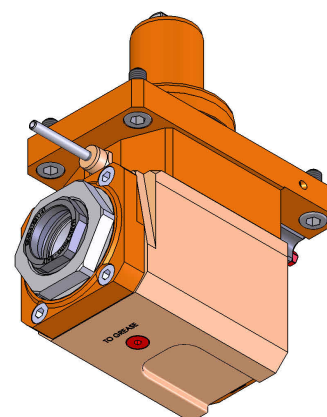
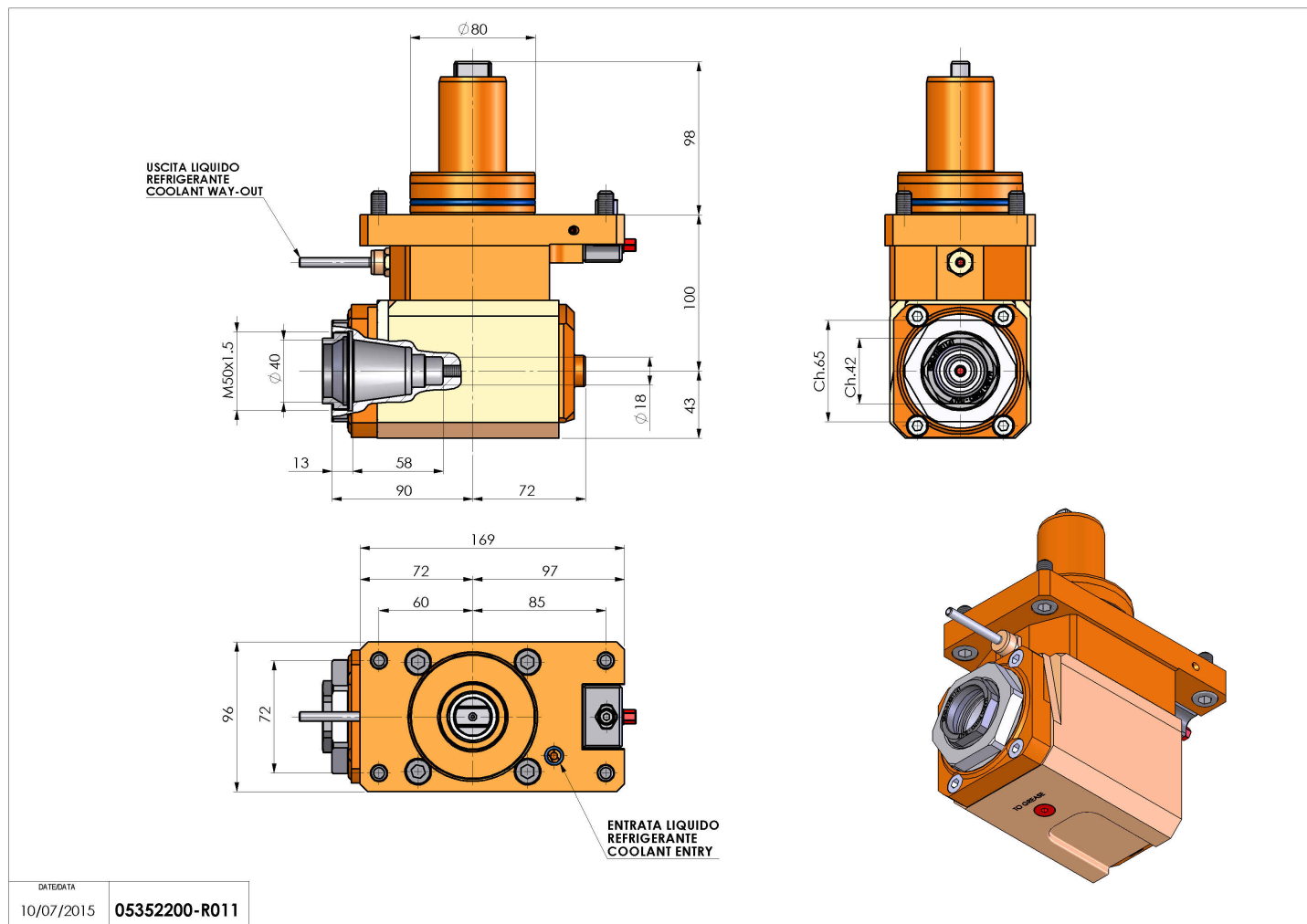

Subject to technical changes

DATE/DATE	05352200-R011
10/07/2015	