



05352100 - LT-A D80 ER40F RF H100 MZ

Type	LT-A Tool holder angle 90°
Mounting	CYLINDRICAL SHANK 80
Tool output	Collet nut ER 40 F - internal nut
Coolant	Internal coolant
Direction of rotation	r1  r2 
Max speed [rpm]	6000
Max torque [Nm]	80
Ratio	1:1
H [mm]	100
H1 [mm]	43
Max pressure [bar]	20
Accessories	N.A.
Notes	N.A.
Mounting tips	N.A.



Always check live tool dimensions on the turret

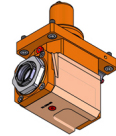
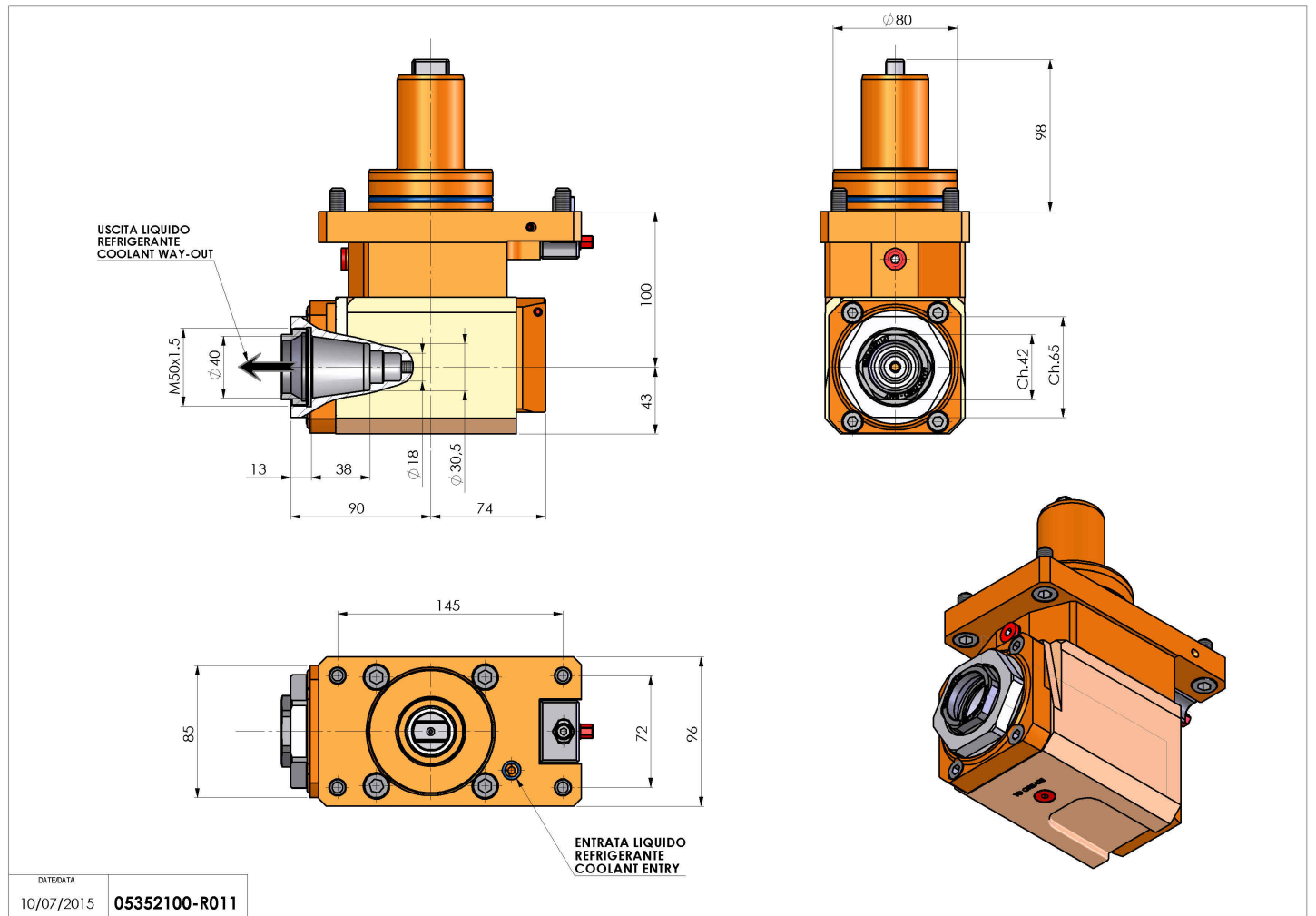

Subject to technical changes

DATE/DATE
10/07/2015 05352100-R011