

05352000 - LT-S D80 ER32F OFS100 RF H96MZ

Type	LT-S OFS Tool holder straight offset
Mounting	CYLINDRICAL SHANK 80
Tool output	Collet nut ER 32 F - internal nut
Coolant	Internal coolant
Offset [mm]	100
Direction of rotation	r1 ↻ r2 ↻
Max speed [rpm]	6000
Max torque [Nm]	80
Ratio	1:1
H [mm]	95,5
Max pressure [bar]	20
Accessories	N.A.
Notes	N.A.
Mounting tips	N.A.

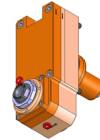

Always check live tool dimensions on the turret

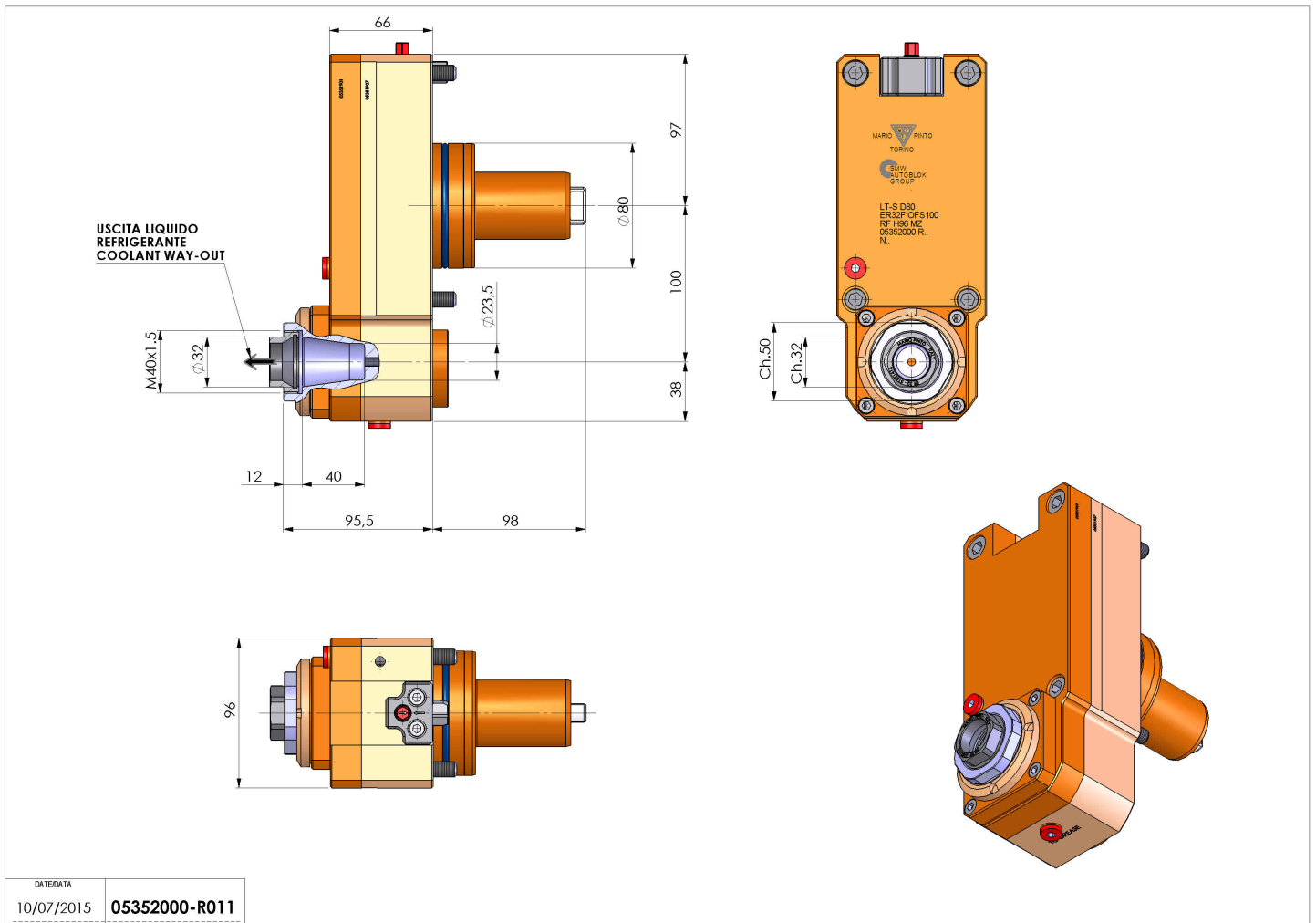

DATE/DATA	10/07/2015	05352000-R011
-----------	------------	---------------

Subject to technical changes