

05339100 - LT-A BMT45 ER20F OFS-16 LR HRF 1:1 H85

Type	LT-A OFS Tool holder offset angle 90°
Mounting	BMT 45
Tool output	Collet nut ER 20 F - internal nut
Coolant	HRF Internal coolant
Direction of rotation	r1 ↻ r2 ↻
Max speed [rpm]	6000
Max torque [Nm]	25
Ratio	1:1
H [mm]	85
H1 [mm]	32.5
Max pressure [bar]	80
Accessories	N.A.
Notes	N.A.
Mounting tips	Main and secondary spindle

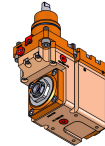

Always check live tool dimensions on the turret

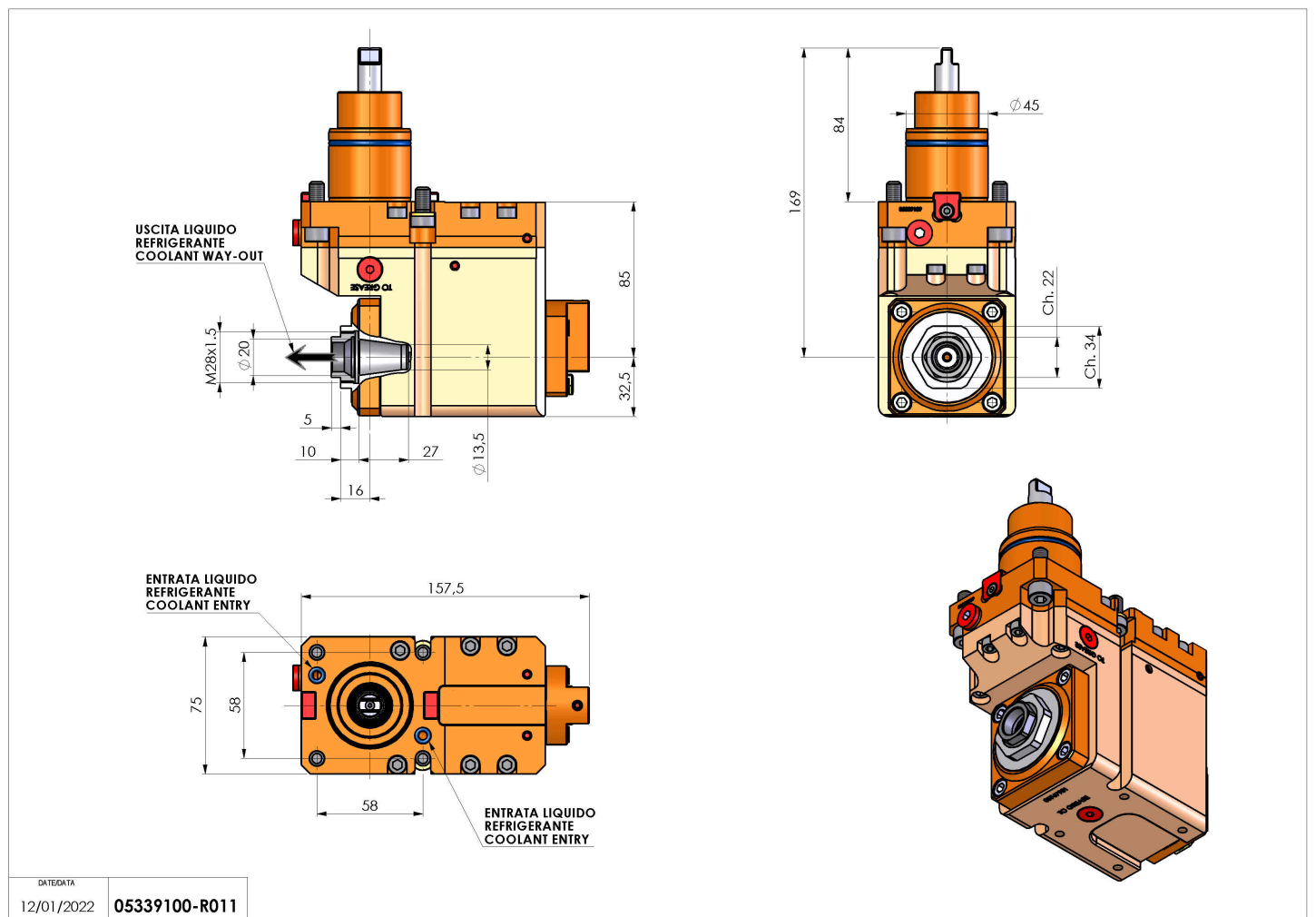

Subject to technical changes

DATE/DATE
12/01/2022 05339100-R011