

05333000 - LT-S BMT85 ISO-BT40 OFS110 RF LR 2:1 H80

Type	LT-S OFS Tool holder straight offset
Mounting	BMT 85
Tool output	Quick Change ISO-BT40
Coolant	Internal coolant
Offset [mm]	110
Direction of rotation	r1 r2
Max speed [rpm]	in 4000 / out 2000
Max torque [Nm]	in 90 / out 180
Ratio	2:1
H [mm]	80
Max pressure [bar]	20
Accessories	N.A.
Notes	N.A.
Mounting tips	N.A.

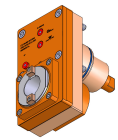

Always check live tool dimensions on the turret

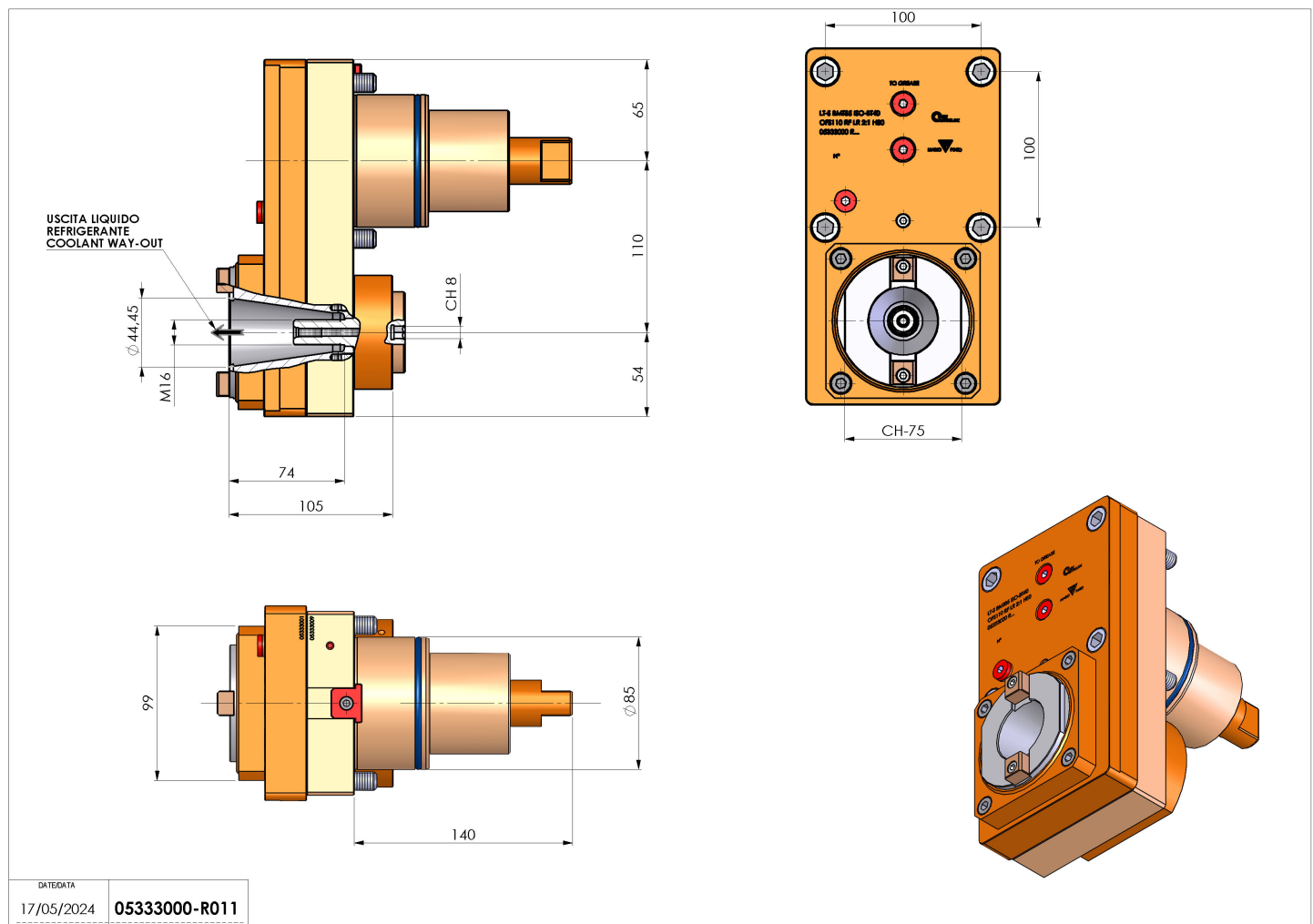

Subject to technical changes