

# 05332100 - LT-A BMT65 ER32-32F LR H100

<b>Type</b>	LT-A DBL Tool holder double angle 90°
<b>Mounting</b>	BMT 65
<b>Tool output</b>	Collet nut ER 32 F - internal nut
<b>Coolant</b>	External coolant
<b>Direction of rotation</b>	r1 ↻ r2 ↻ r3 ↻
<b>Max speed [rpm]</b>	6000
<b>Max torque [Nm]</b>	63
<b>Ratio</b>	1:1
<b>H [mm]</b>	100
<b>H1 [mm]</b>	38
<b>Accessories</b>	N.A.
<b>Notes</b>	N.A.
<b>Mounting tips</b>	N.A.

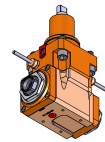

Always check live tool dimensions on the turret

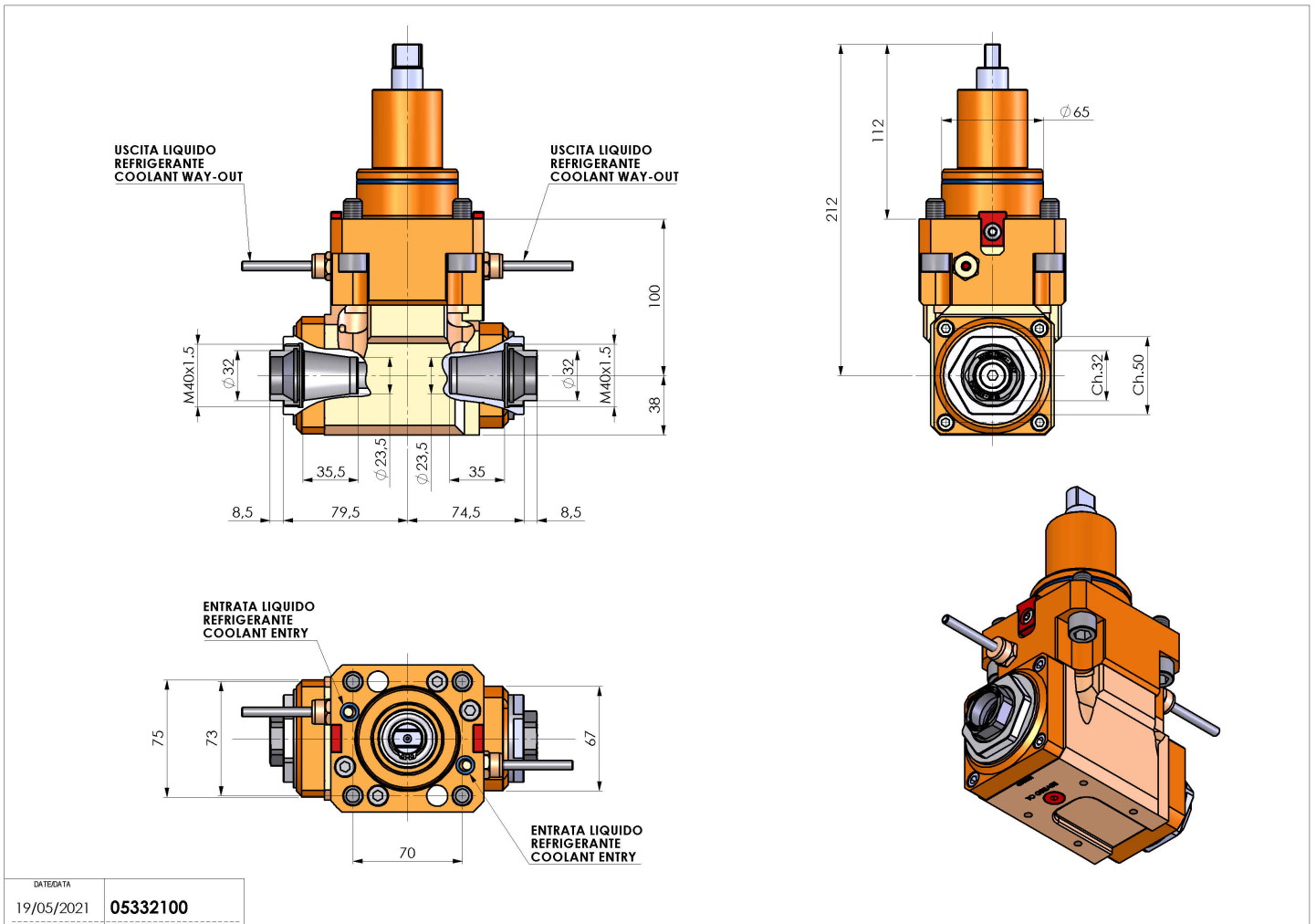

DATE/DATA	19/05/2021
	05332100

Subject to technical changes