

# 05306800 - LT-A BMT85 ER50 LR RF 2:1 H85

Type	LT-A Tool holder angle 90°
Mounting	BMT 85
Tool output	Collet nut ER 50
Coolant	Internal coolant
Direction of rotation	r1 ↻ r2 ↻
Max speed [rpm]	in 4000 / out 2000
Max torque [Nm]	in 120 / out 240
Ratio	2:1
H [mm]	85
H1 [mm]	52
Max pressure [bar]	20
Accessories	N.A.
Notes	N.A.
Mounting tips	N.A.

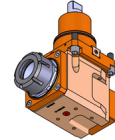

Always check live tool dimensions on the turret

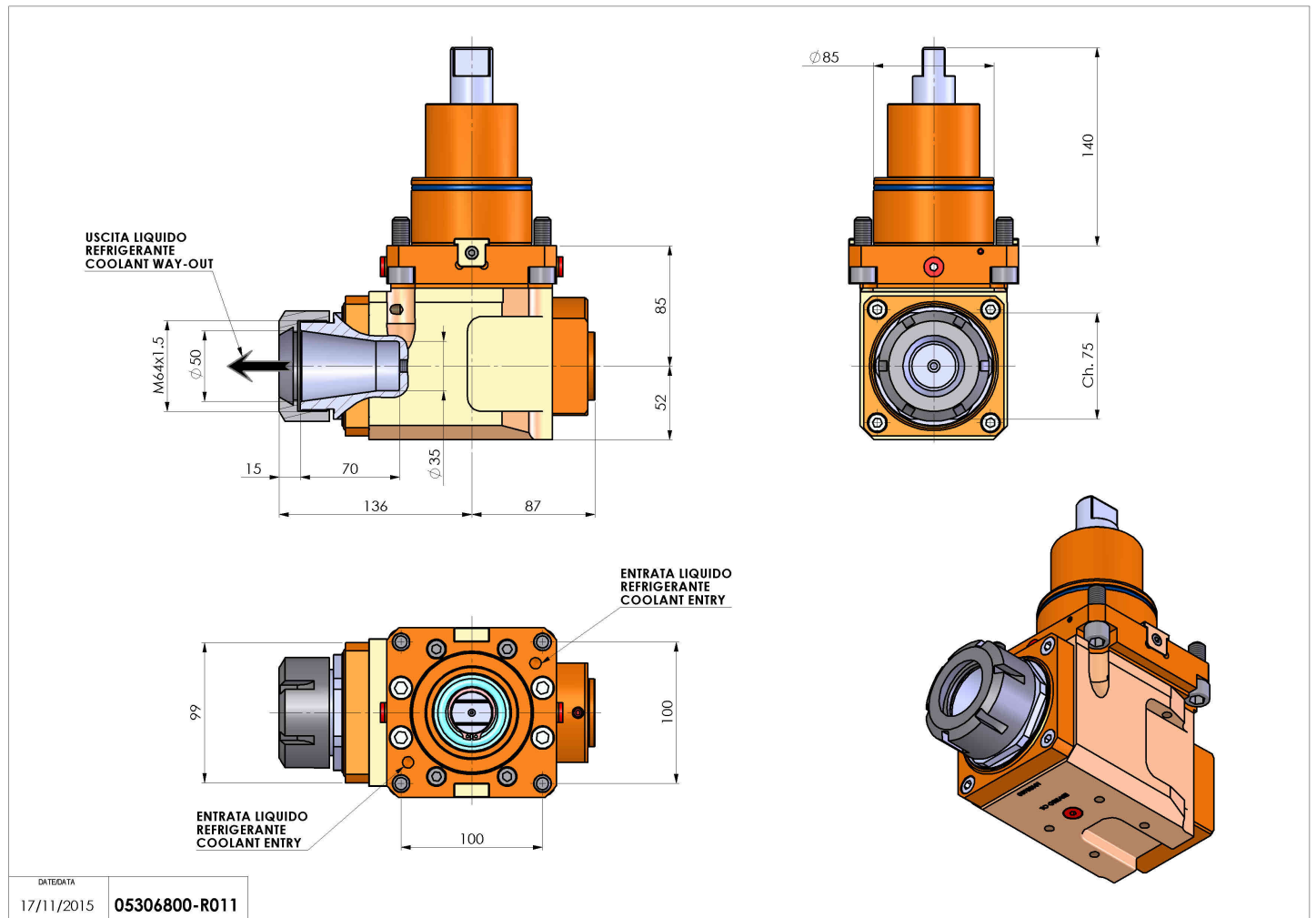

DATE/DATE	17/11/2015	05306800-R011
-----------	------------	---------------

Subject to technical changes