



05306700 - LT-A2 BMT85 ER32F-32F H53-129

Type	LT-A2 V Tool holder angle 90° double vertical
Mounting	BMT 85
Tool output	Collet nut ER 32 F - internal nut
Coolant	External coolant
Offset [mm]	76
Direction of rotation	r1  r2 
Max speed [rpm]	4000
Max torque [Nm]	50
Ratio	1:1
H [mm]	53-129
H1 [mm]	39
Accessories	N.A.
Notes	
Mounting tips	N.A.



Always check live tool dimensions on the turret

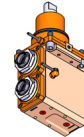
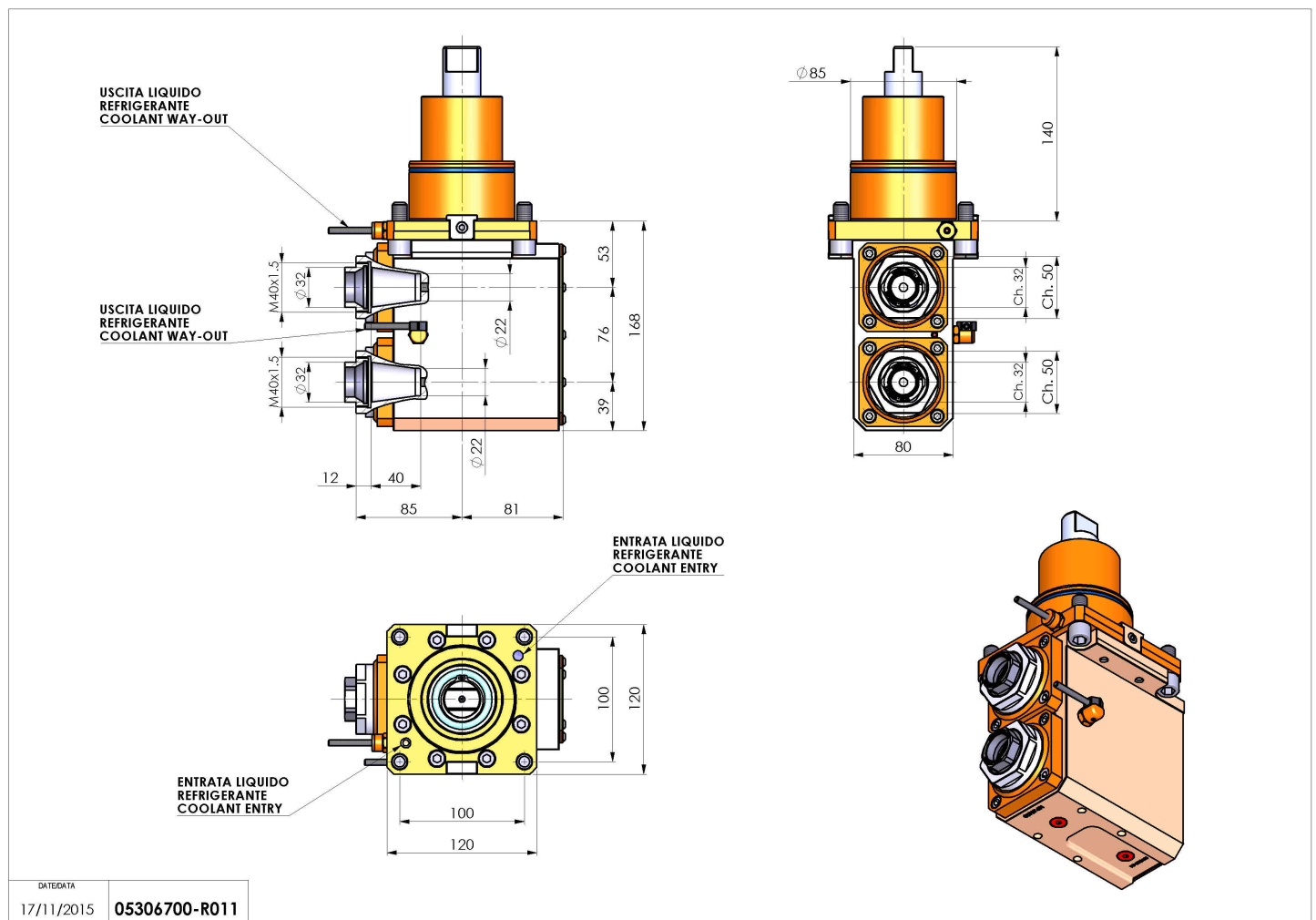

DATE/DATA
17/11/2015 05306700-R011

Subject to technical changes