

05303400 - LT-S BMT65 HSK63 RF H88

Type	LT-S Tool holder straight
Mounting	BMT 65
Tool output	Quick Change HSK63
Coolant	Internal coolant
Direction of rotation	r1 r2
Max speed [rpm]	6000
Max torque [Nm]	70
Ratio	1:1
H [mm]	88
Max pressure [bar]	20
Accessories	
Notes	N.A.
Mounting tips	N.A.

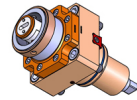

Always check live tool dimensions on the turret

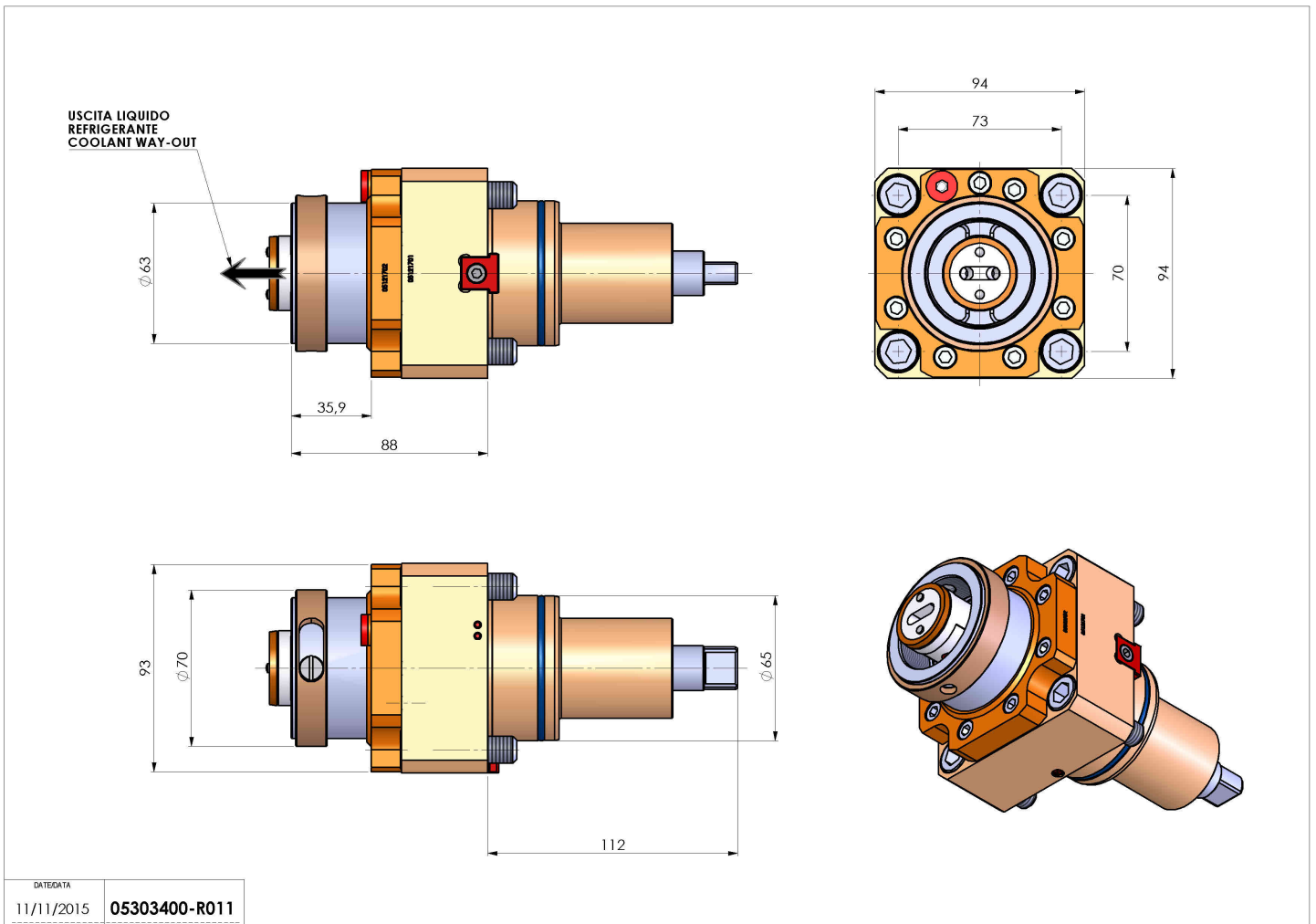

DATE/DATE	05303400-R011
11/11/2015	

Subject to technical changes