

05302900 - LT-S BMT55 HSK40 OFS75 2:1 H95

Type	LT-S OFS Tool holder straight offset
Mounting	BMT 55
Tool output	Quick Change HSK40
Coolant	External coolant
Offset [mm]	75
Direction of rotation	r1 ↻ r2 ↻
Max speed [rpm]	in 6000 / out 3000
Max torque [Nm]	in 40 / out 80
Ratio	2:1
H [mm]	95
Accessories	N.A.
Notes	N.A.
Mounting tips	N.A.

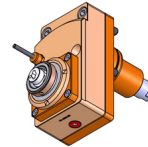

Always check live tool dimensions on the turret

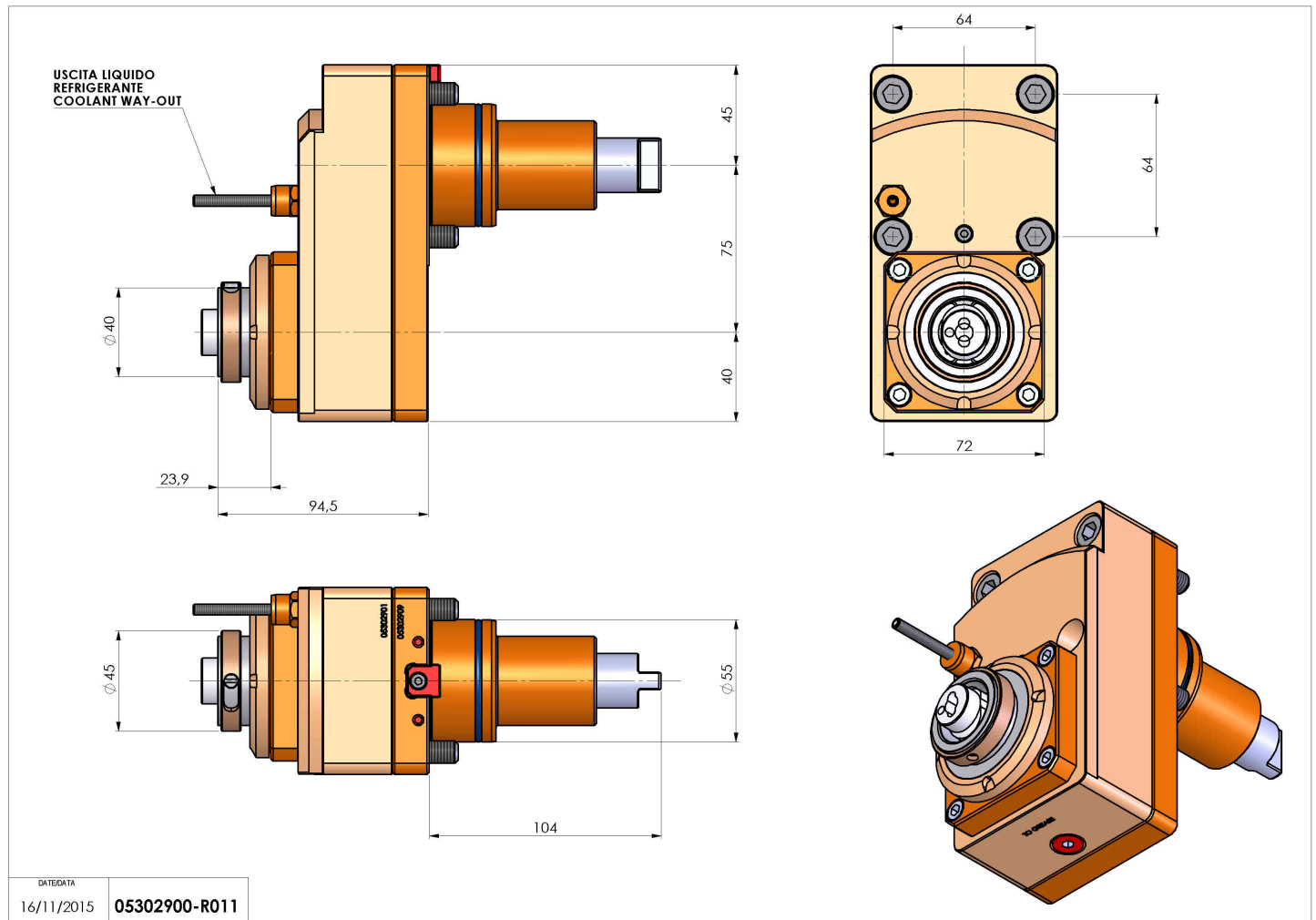

Subject to technical changes