

## 05302500 - LT-A BMT55 DIN138-22 LR H85

<b>Type</b>	LT-A Tool holder angle 90°
<b>Mounting</b>	BMT 55
<b>Tool output</b>	Shell-Mill DIN138 22
<b>Coolant</b>	External coolant
<b>Direction of rotation</b>	r1  r2
<b>Max speed [rpm]</b>	6000
<b>Max torque [Nm]</b>	40
<b>Ratio</b>	1:1
<b>H [mm]</b>	85
<b>H1 [mm]</b>	32,5
<b>Accessories</b>	N.A.
<b>Notes</b>	N.A.
<b>Mounting tips</b>	N.A.

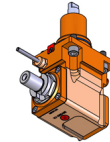

Always check live tool dimensions on the turret

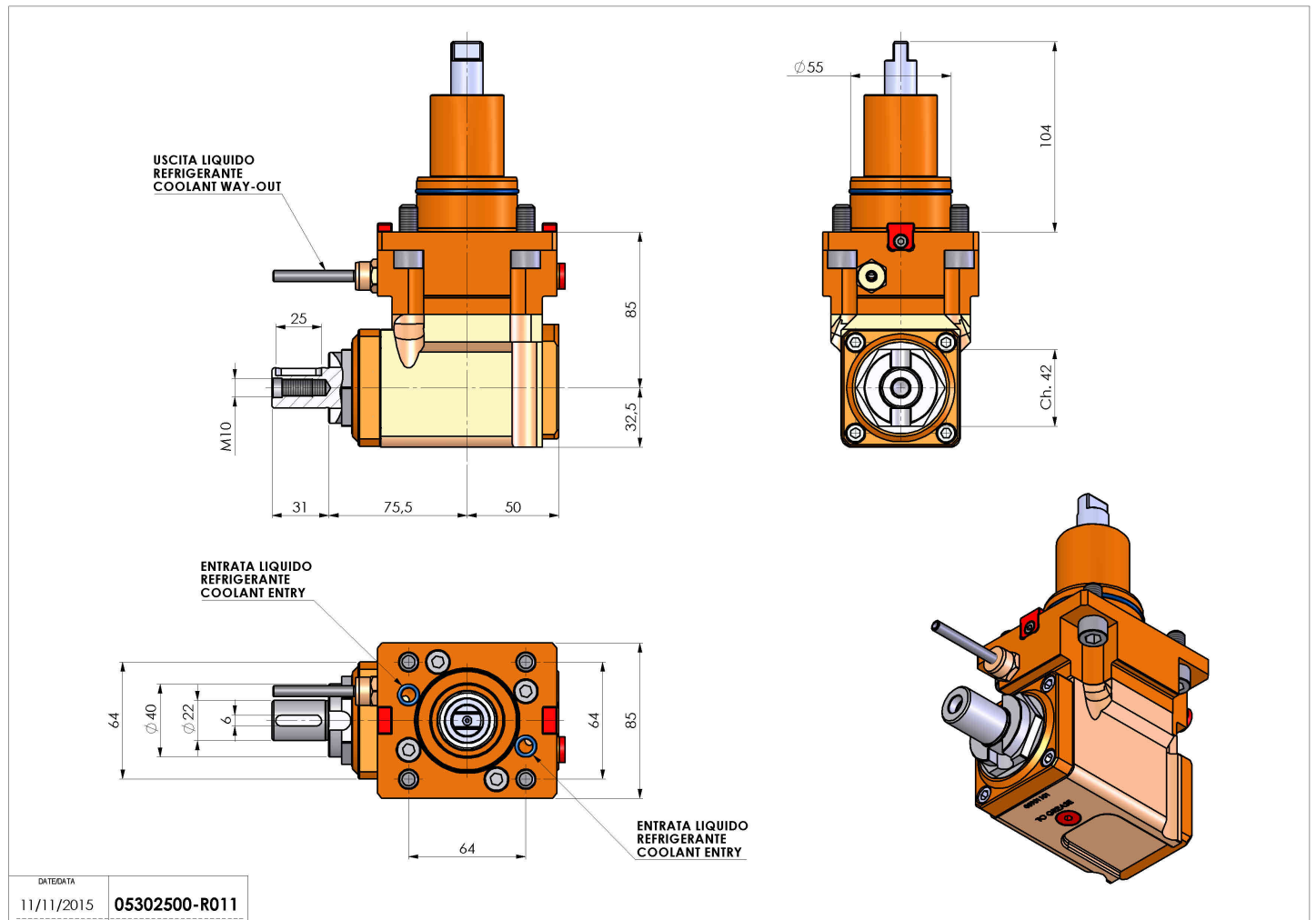

DATE/DATE	11/11/2015
PART NUMBER	05302500-R011

Subject to technical changes