

## 05301500 - LT-A BMT55 ER25 1:2 KR H70

<b>Type</b>	LT-A Tool holder angle 90°
<b>Mounting</b>	BMT 55
<b>Tool output</b>	Collet nut ER 25
<b>Coolant</b>	With coolant kit
<b>Direction of rotation</b>	r1  r2
<b>Max speed [rpm]</b>	in 6000 / out 12000
<b>Max torque [Nm]</b>	in 60 / out 30
<b>Ratio</b>	1:2
<b>H [mm]</b>	70
<b>H1 [mm]</b>	32,5
<b>Accessories</b>	N.A.
<b>Notes</b>	N.A.
<b>Mounting tips</b>	N.A.

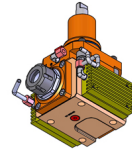

Always check live tool dimensions on the turret

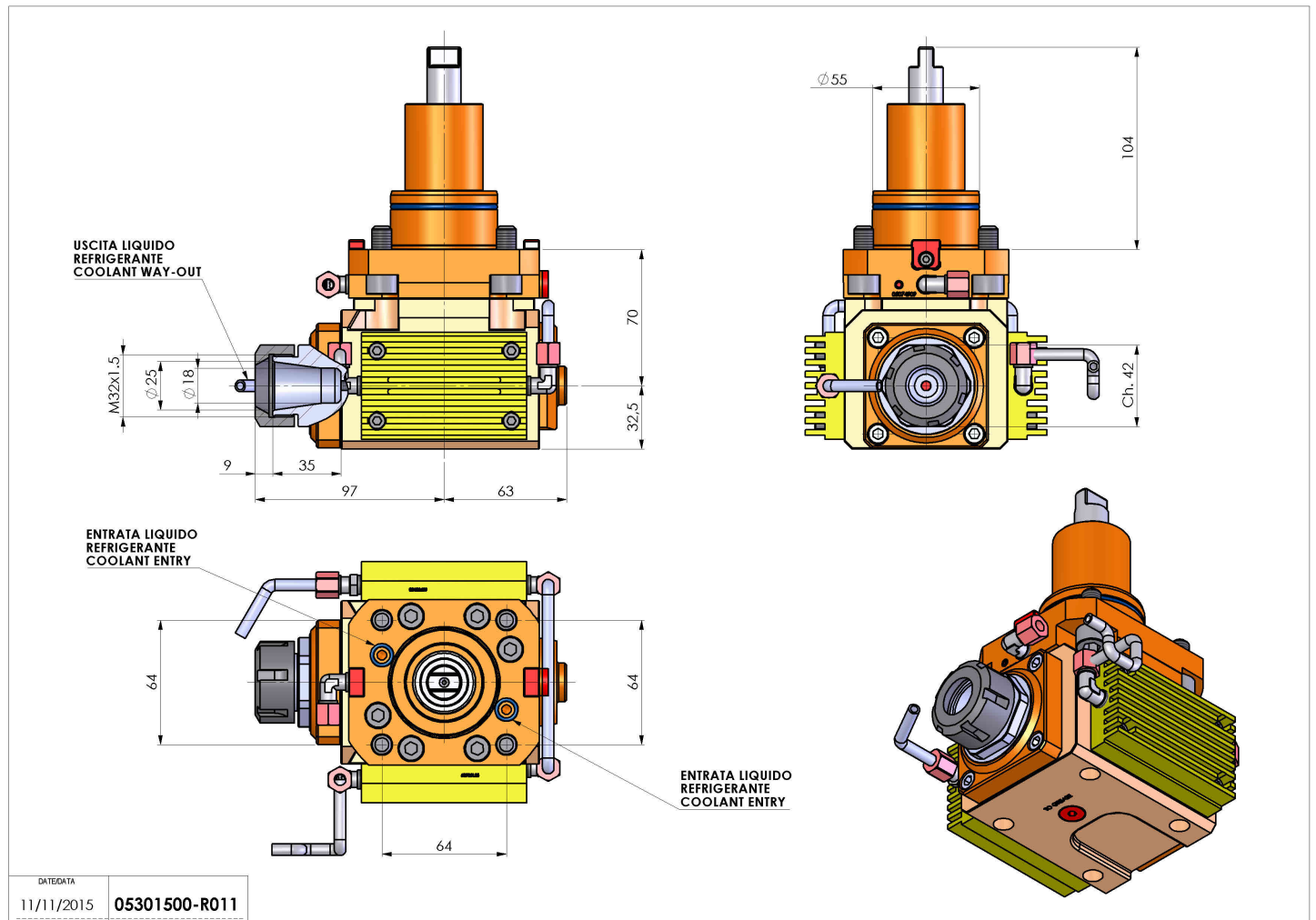

DATE/DATE	11/11/2015
PART NUMBER	05301500-R011

Subject to technical changes