



## 05300100 - LT-A BMT45 ER20F OFS 1:1 LR H100

<b>Type</b>	LT-A OFS Tool holder offset angle 90°
<b>Mounting</b>	BMT 45
<b>Tool output</b>	Collet nut ER 20 F - internal nut
<b>Coolant</b>	External coolant
<b>Direction of rotation</b>	r1  r2 
<b>Max speed [rpm]</b>	6000
<b>Max torque [Nm]</b>	25
<b>Ratio</b>	1:1
<b>H [mm]</b>	100
<b>H1 [mm]</b>	32,5
<b>Accessories</b>	N.A.
<b>Notes</b>	N.A.
<b>Mounting tips</b>	Main and secondary spindle



Always check live tool dimensions on the turret

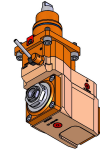
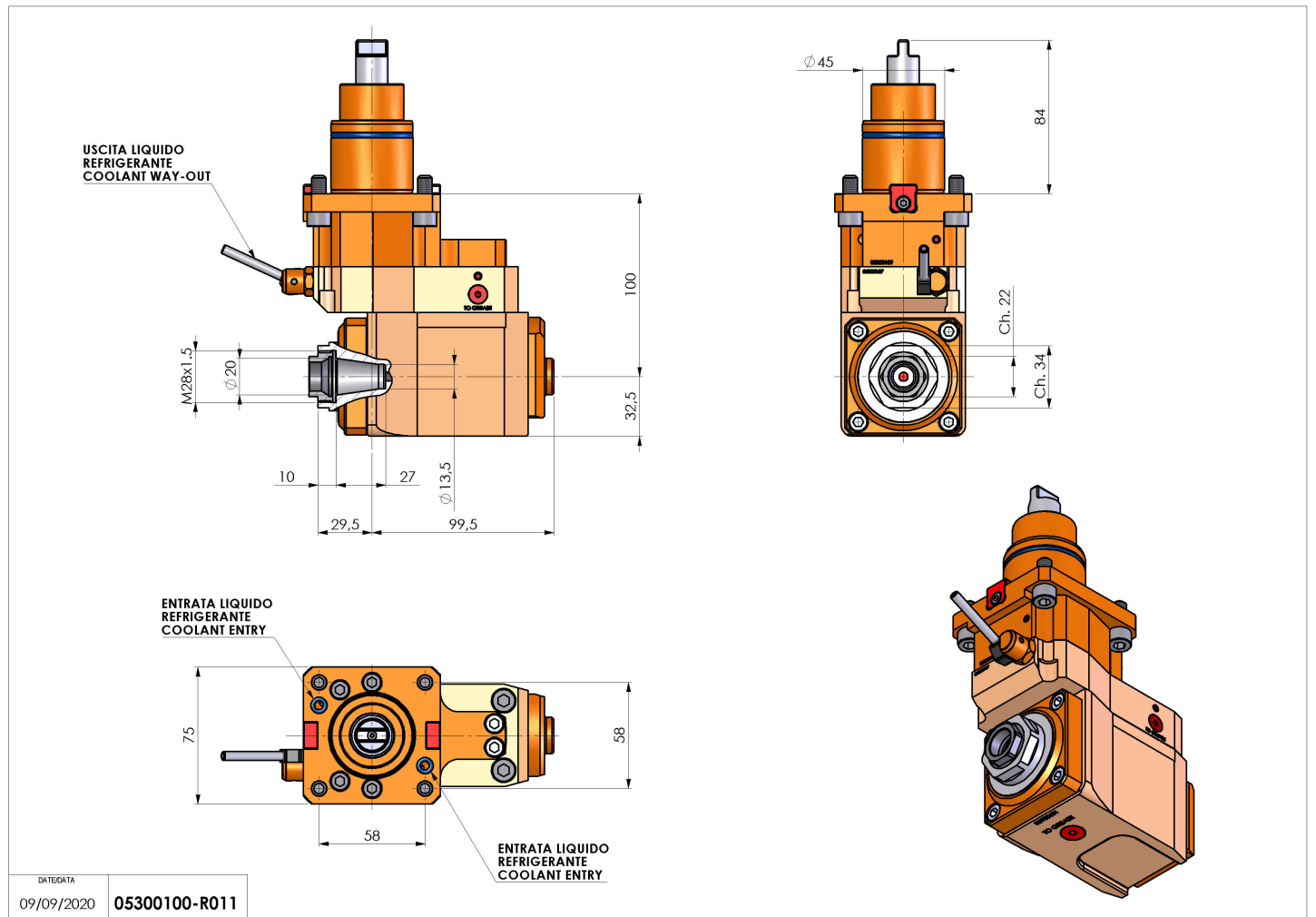

Subject to technical changes