

05292900 - LT-A D32 ER32 HS H60 SEC

Type	LT-A Tool holder angle 90°
Mounting	CYLINDRICAL SHANK 32
Tool output	Collet nut ER 32
Coolant	External coolant
Direction of rotation	r1 r2
Max speed [rpm]	12000
Max torque [Nm]	70
Ratio	1:1
H [mm]	60
H1 [mm]	37
Accessories	N.A.
Notes	N.A.
Mounting tips	Secondary spindle only

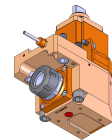

Always check live tool dimensions on the turret

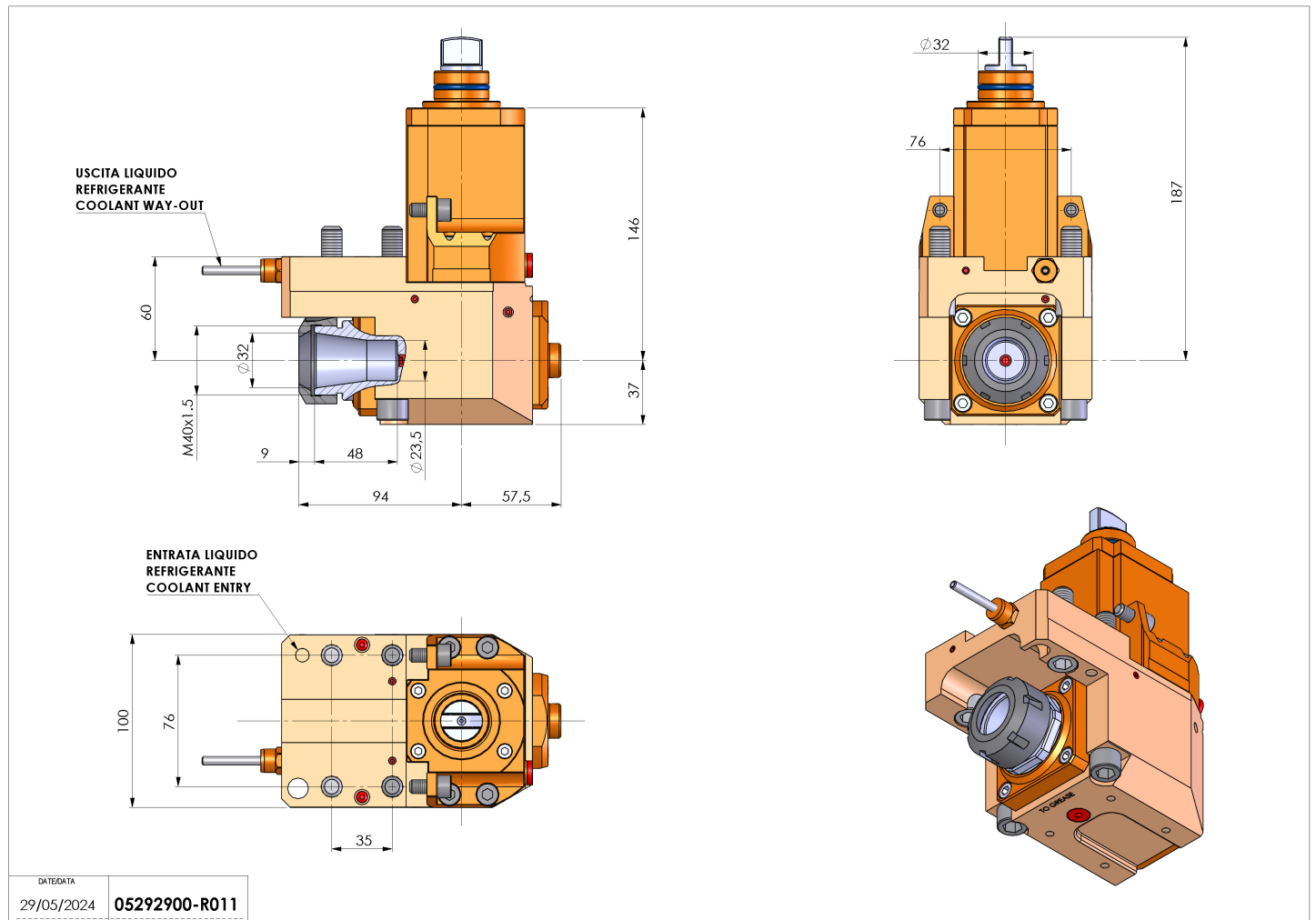

DATE/DATE: 29/05/2024 **05292900-R011**

Subject to technical changes