

## 05290100 - LT-S D32 ER32 RF H65

Type	LT-S Tool holder straight
Mounting	CYLINDRICAL SHANK 32
Tool output	Collet nut ER 32
Coolant	Internal coolant
Direction of rotation	r1 ↻ r2 ↻
Max speed [rpm]	6000
Max torque [Nm]	70
Ratio	1:1
H [mm]	65
Max pressure [bar]	20
Accessories	N.A.
Notes	N.A.
Mounting tips	N.A.

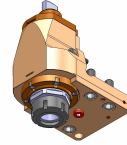

Always check live tool dimensions on the turret

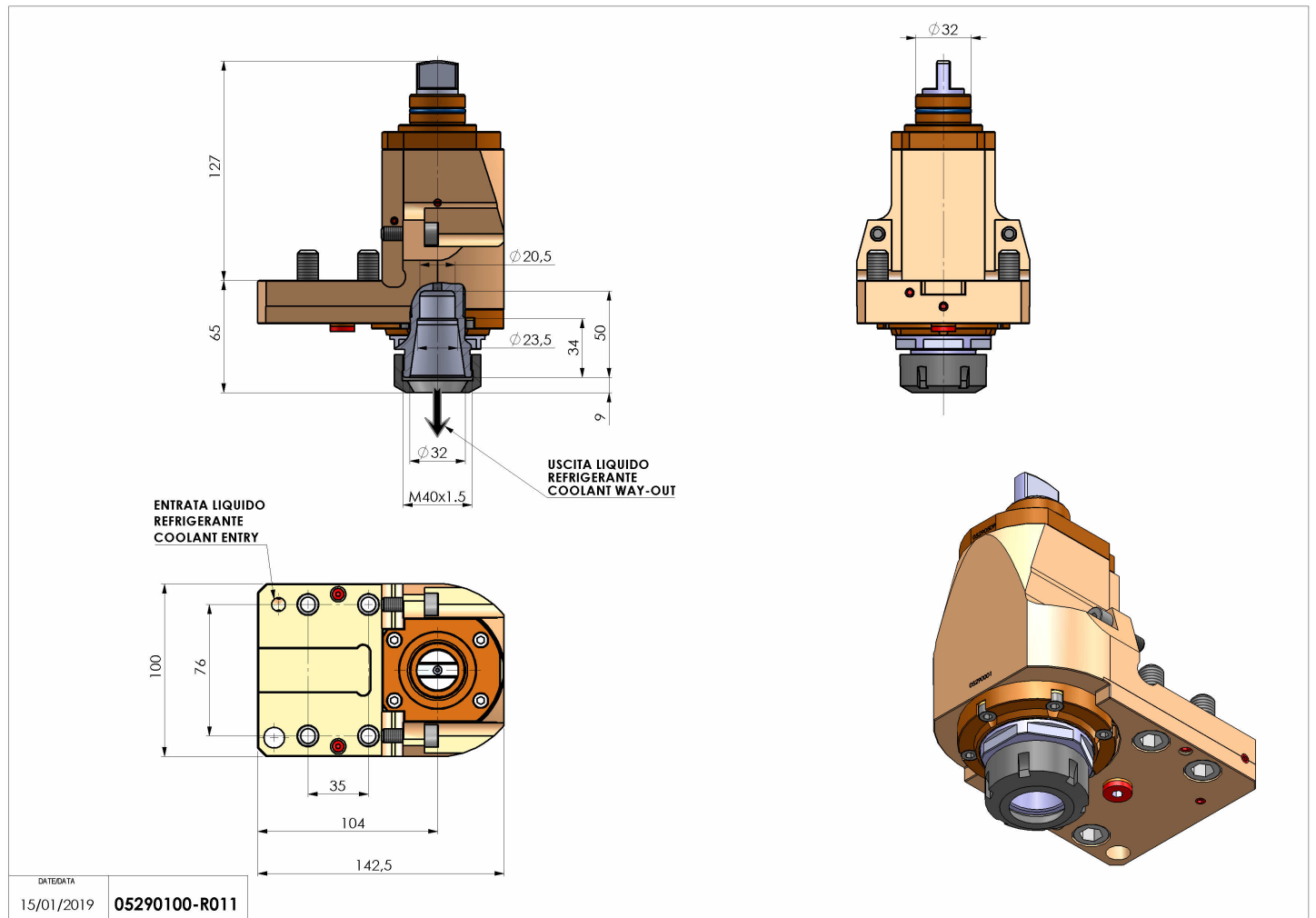

Subject to technical changes

DATE/DATE  
15/01/2019 05290100-R011