

05261000 - LT-A ST65 D60 C16 CR-AY H105 OK

Type	LT-A ST Slotting tool 90°
Mounting	CYLINDRICAL SHANK 60
Tool output	Tool diameter 16
Coolant	External coolant
Max speed [rpm]	500
Ratio	1:1
Y axis adjustment	SI
Feed pushing [N]	30
Stroke [mm]	65
Work stroke [mm]	60
Y axis adjust. [mm]	±0,4
H [mm]	105
Accessories	N.A.
Notes	N.A.
Mounting tips	N.A.

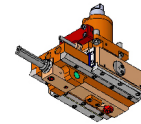

Always check live tool dimensions on the turret

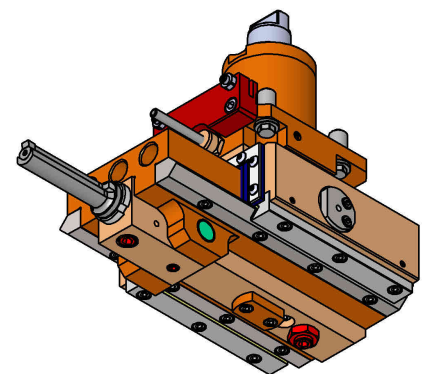
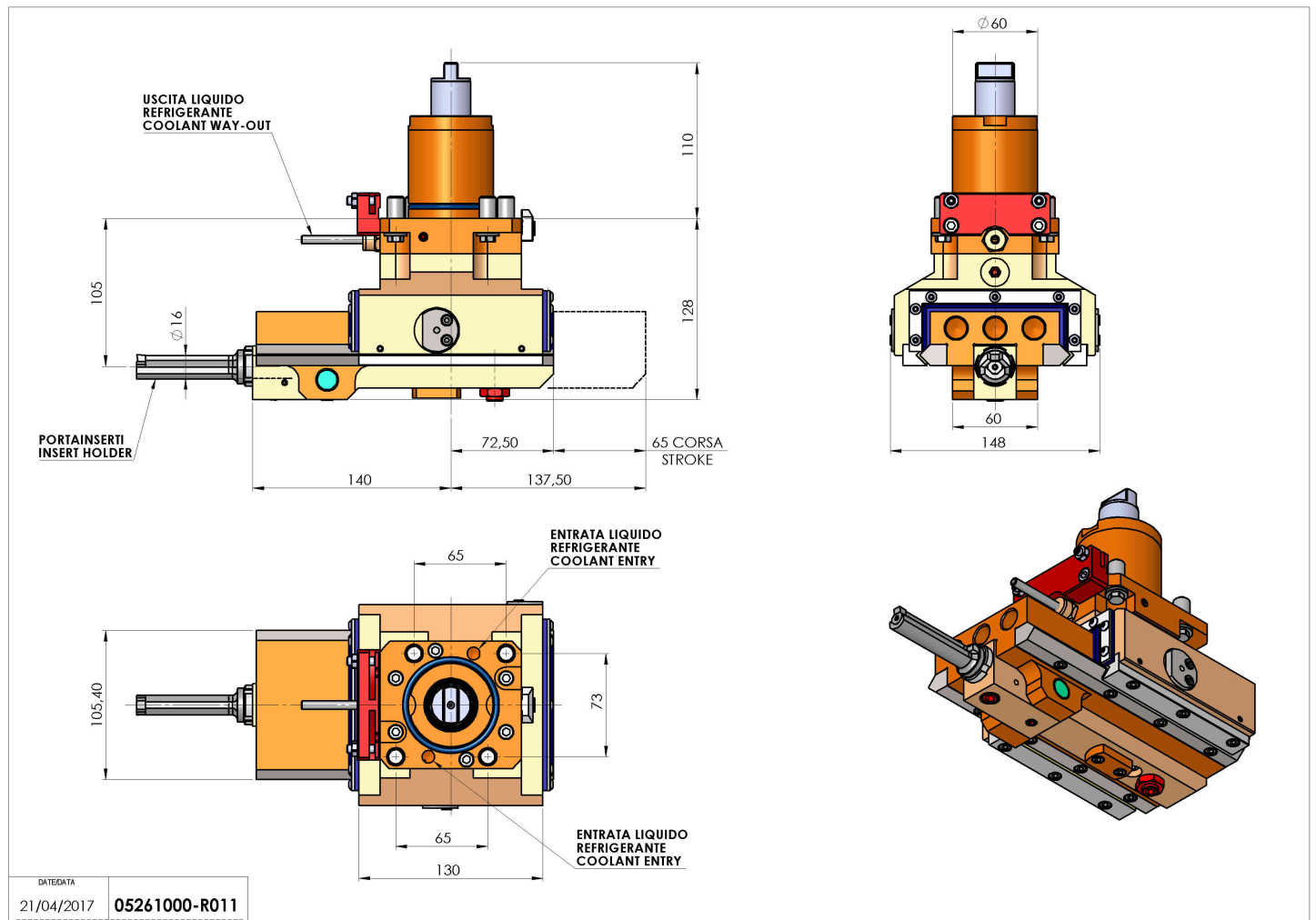

DATE/DATE: 21/04/2017
05261000-R011

Subject to technical changes