



# 05259600 - LT-SVDI40C4OFS50 HRF H114MZ

<b>Type</b>	LT-S OFS Tool holder straight offset
<b>Mounting</b>	VDI 40
<b>Tool output</b>	Polygonal shank C40 ISO 26623-1
<b>Coolant</b>	Internal coolant
<b>Offset [mm]</b>	50
<b>Direction of rotation</b>	r1  r2 
<b>Max speed [rpm]</b>	6000
<b>Max torque [Nm]</b>	63
<b>Ratio</b>	1:1
<b>H [mm]</b>	114
<b>Tool length [mm]</b>	56
<b>Max pressure [bar]</b>	20
<b>Accessories</b>	N.A.
<b>Notes</b>	N.A.
<b>Mounting tips</b>	N.A.

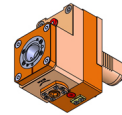

**ATTENTION: CHECK THE ORIENTATION OF THE VDI TEETH**

Always check live tool dimensions on the turret

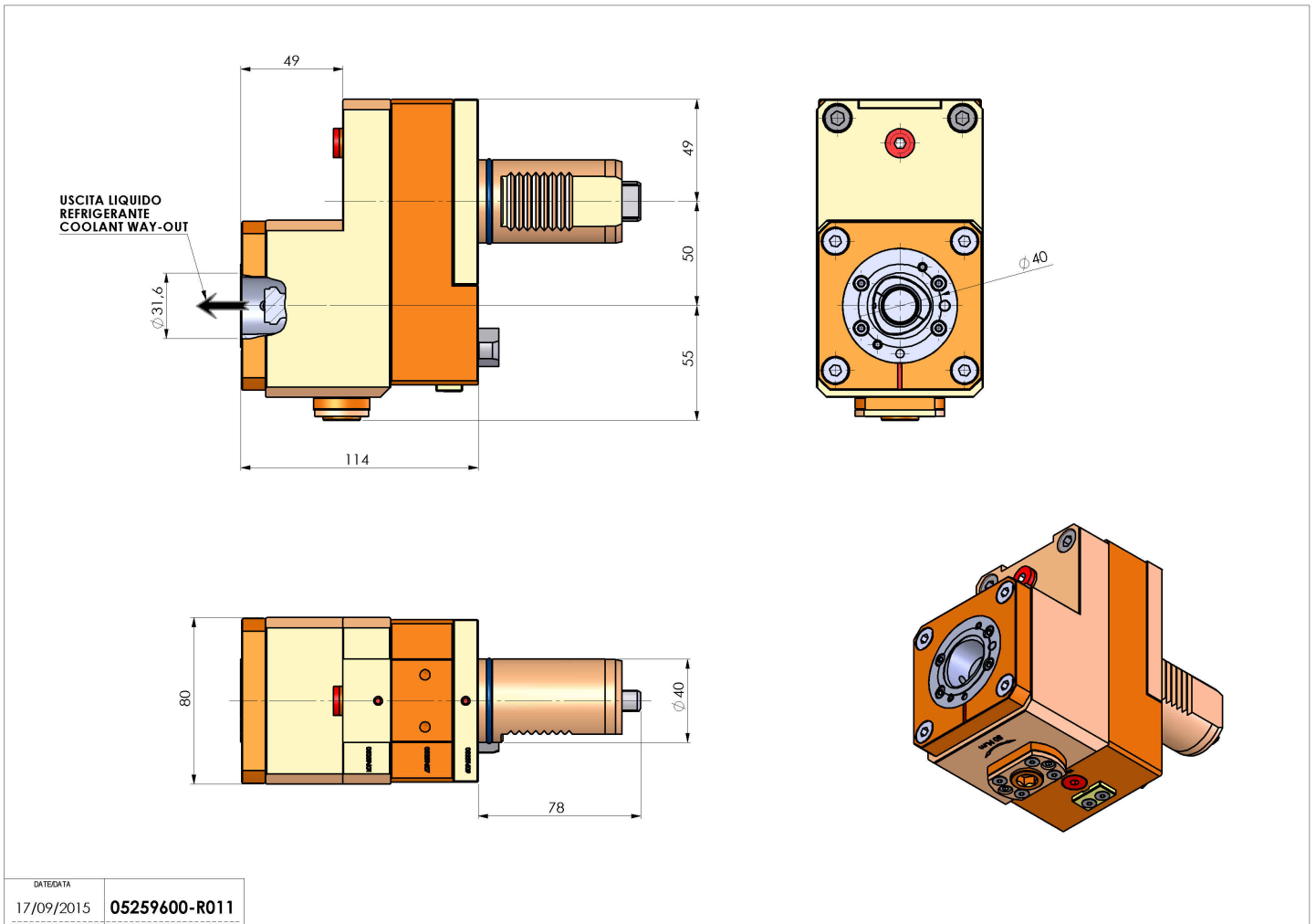

DATE/GRA	05259600-R011
17/09/2015	

Subject to technical changes