

## 05252500 - LT-A VDI50 CAT40V40 L RFH160MZ

|                       |                               |
|-----------------------|-------------------------------|
| Type                  | LT-A<br>Tool holder angle 90° |
| Mounting              | VDI 50                        |
| Tool output           | Quick Change CAT40            |
| Coolant               | Internal coolant              |
| Direction of rotation | r1 ↻ r2 ↻                     |
| Max speed [rpm]       | 6000                          |
| Max torque [Nm]       | 180                           |
| Ratio                 | 1:1                           |
| H [mm]                | 160                           |
| H1 [mm]               | 52                            |
| Max pressure [bar]    | 20                            |
| Accessories           | N.A.                          |
| Notes                 | N.A.                          |
| Mounting tips         | N.A.                          |

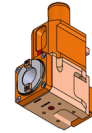

**ATTENTION: CHECK THE ORIENTATION OF THE VDI TEETH**

Always check live tool dimensions on the turret

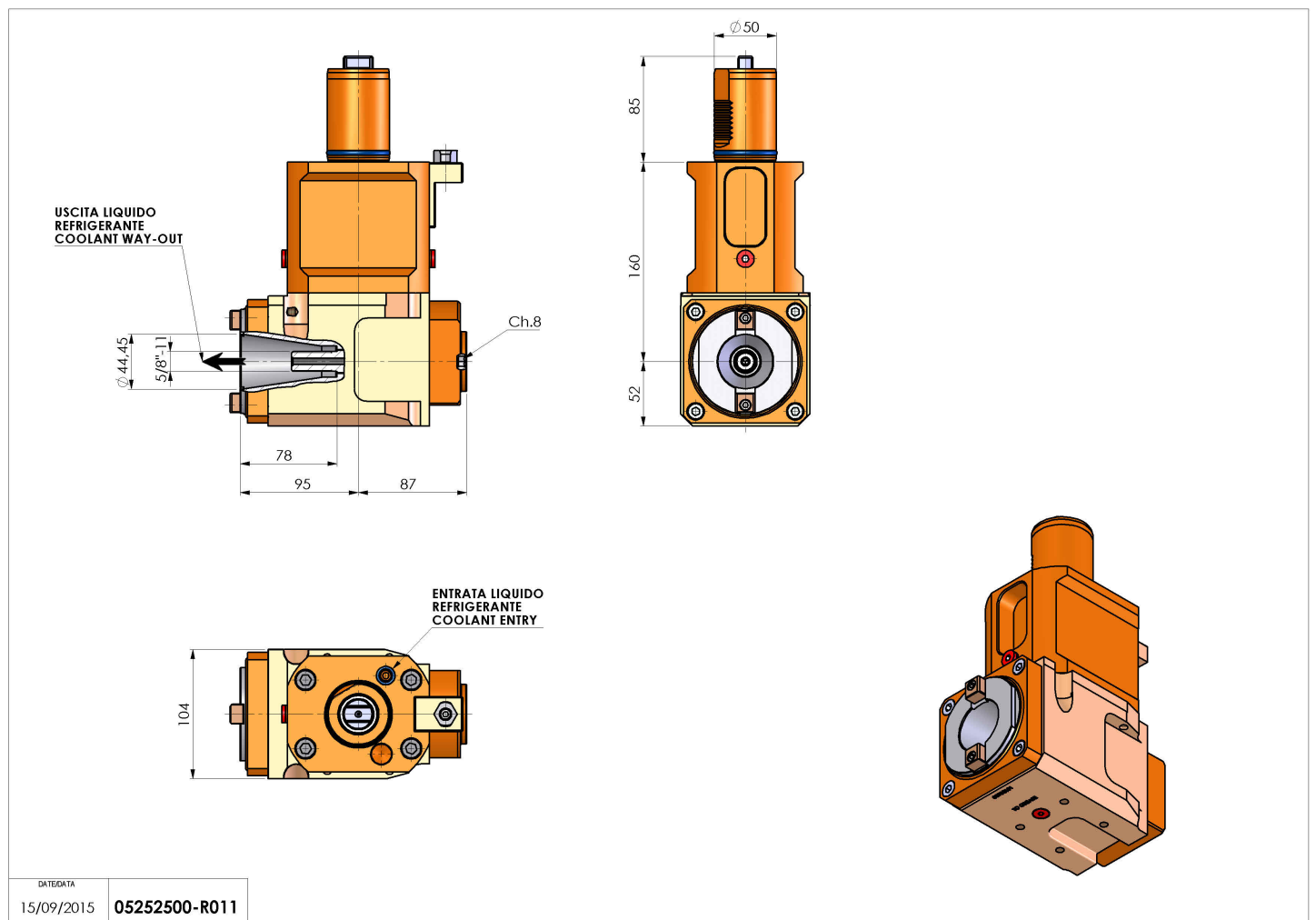

DATE/DATE: 15/09/2015  
05252500-R011

Subject to technical changes