

05240100 - LT-S D60ER32FOF50 1:1HRFHSH102

Type	LT-S OFS Tool holder straight offset
Mounting	CYLINDRICAL SHANK 60
Tool output	Collet nut ER 32 F - internal nut
Coolant	HRF Internal coolant
Offset [mm]	50
Direction of rotation	r1 r2
Max speed [rpm]	10000
Max torque [Nm]	63
Ratio	1:1
H [mm]	102
Max pressure [bar]	80
Accessories	N.A.
Notes	N.A.
Mounting tips	N.A.

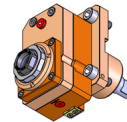

Always check live tool dimensions on the turret

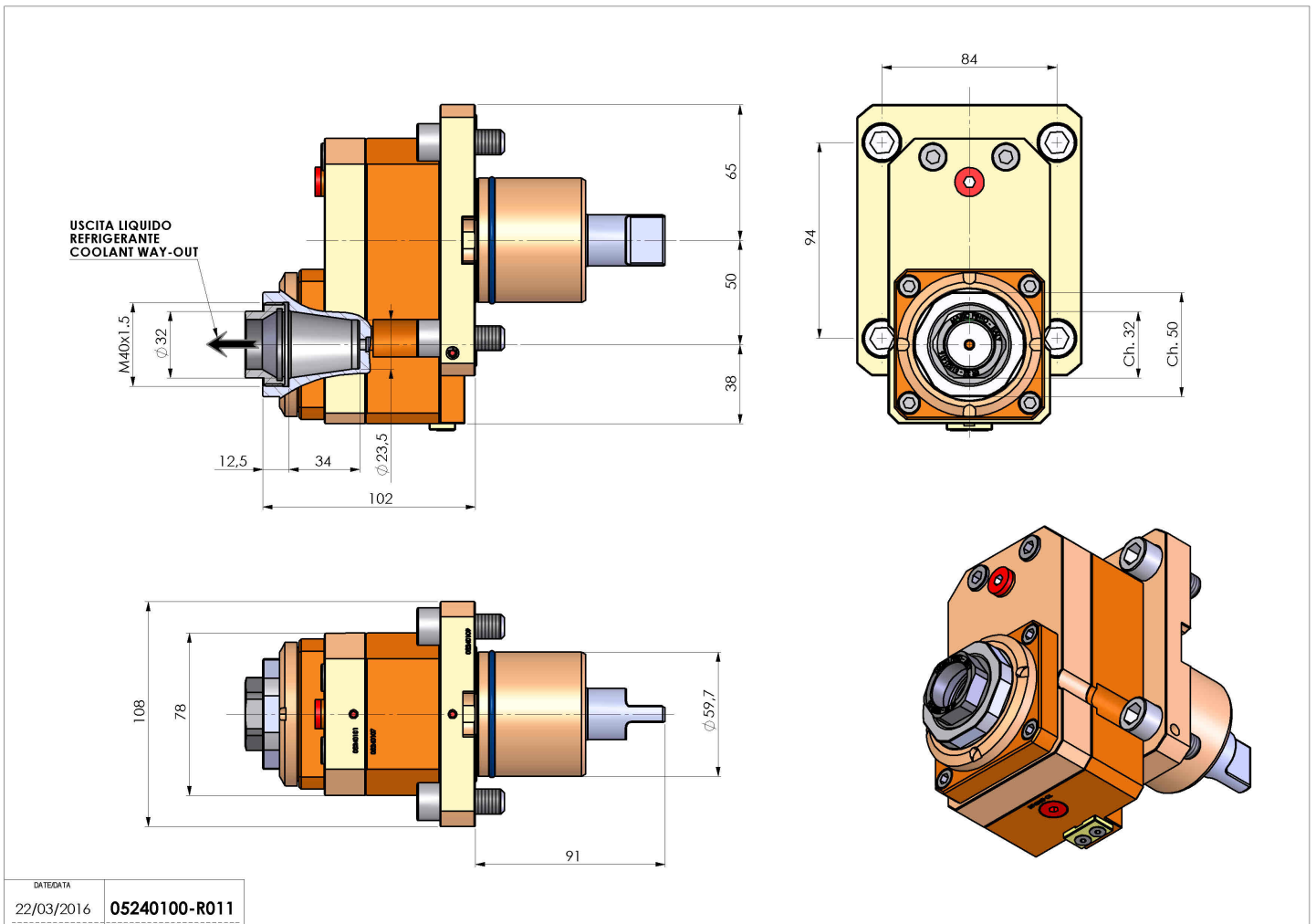

DATE/DATE: 22/03/2016 **05240100-R011**

Subject to technical changes