



05233200 - LT-S BMT65 ER32F H61 EM

Type	LT-S Tool holder straight
Mounting	BMT 65 EM
Tool output	Collet nut ER 32 F - internal nut
Coolant	External coolant
Direction of rotation	r1  r2 
Max speed [rpm]	6000
Max torque [Nm]	70
Ratio	1:1
H [mm]	61
Accessories	N.A.
Notes	N.A.
Mounting tips	N.A.



Always check live tool dimensions on the turret

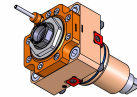
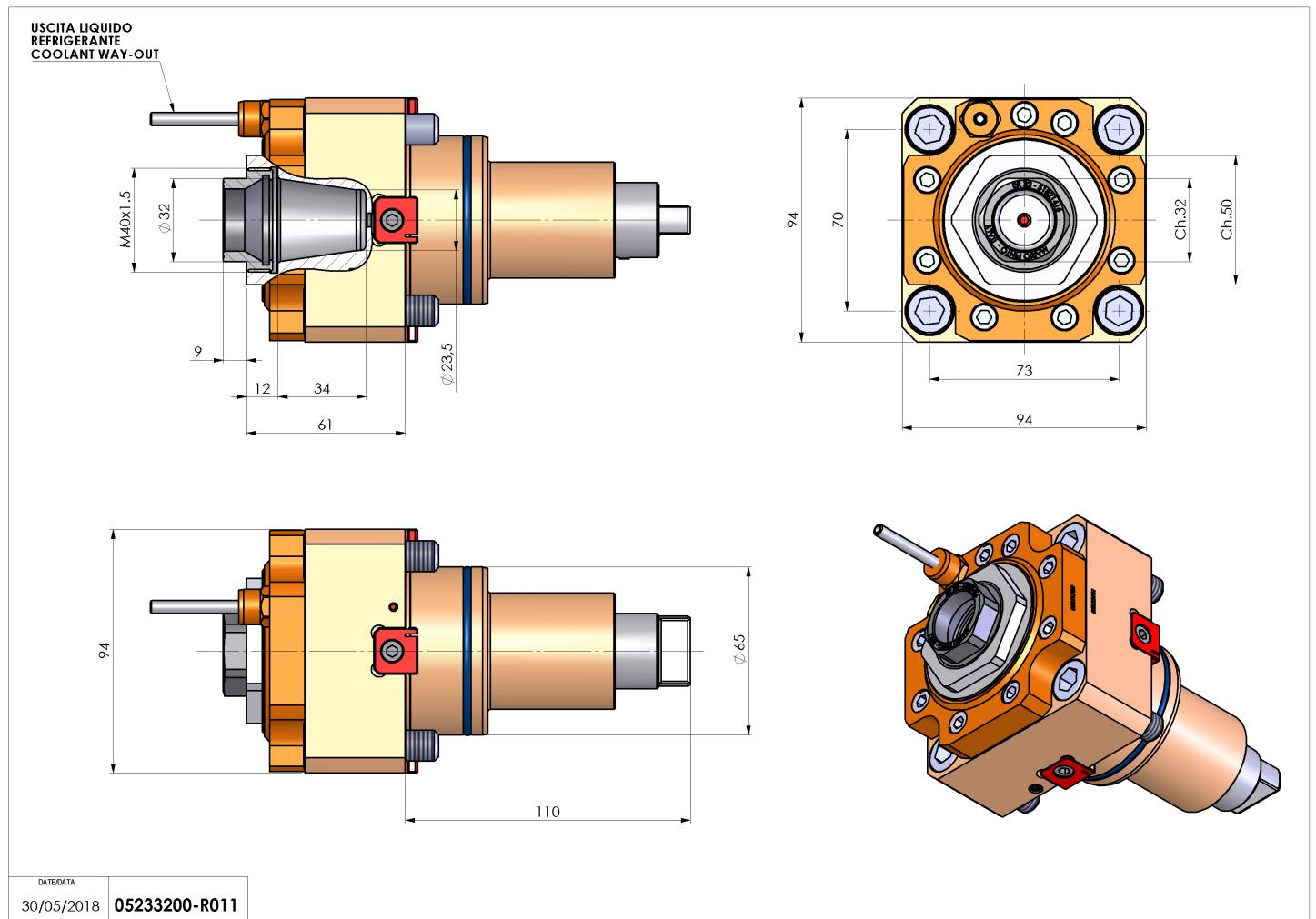

DATE/DATE
30/05/2018 05233200-R011

Subject to technical changes