

05231100 - LT-S2 VDI50ER25F I85.2HRF H120

Type	LT SPECIALE Custom tool holder
Mounting	VDI 50
Tool output	Collet nut ER 25 F - internal nut
Coolant	HRF Internal coolant
Direction of rotation	r1 ↻ r2 ↻ r3 ↻
Max speed [rpm]	6000
Max torque [Nm]	60
Ratio	1:1
H [mm]	120
Max pressure [bar]	80
Accessories	N.A.
Notes	N.A.
Mounting tips	N.A.

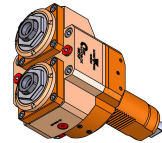

ATTENTION: CHECK THE ORIENTATION OF THE VDI TEETH

Always check live tool dimensions on the turret

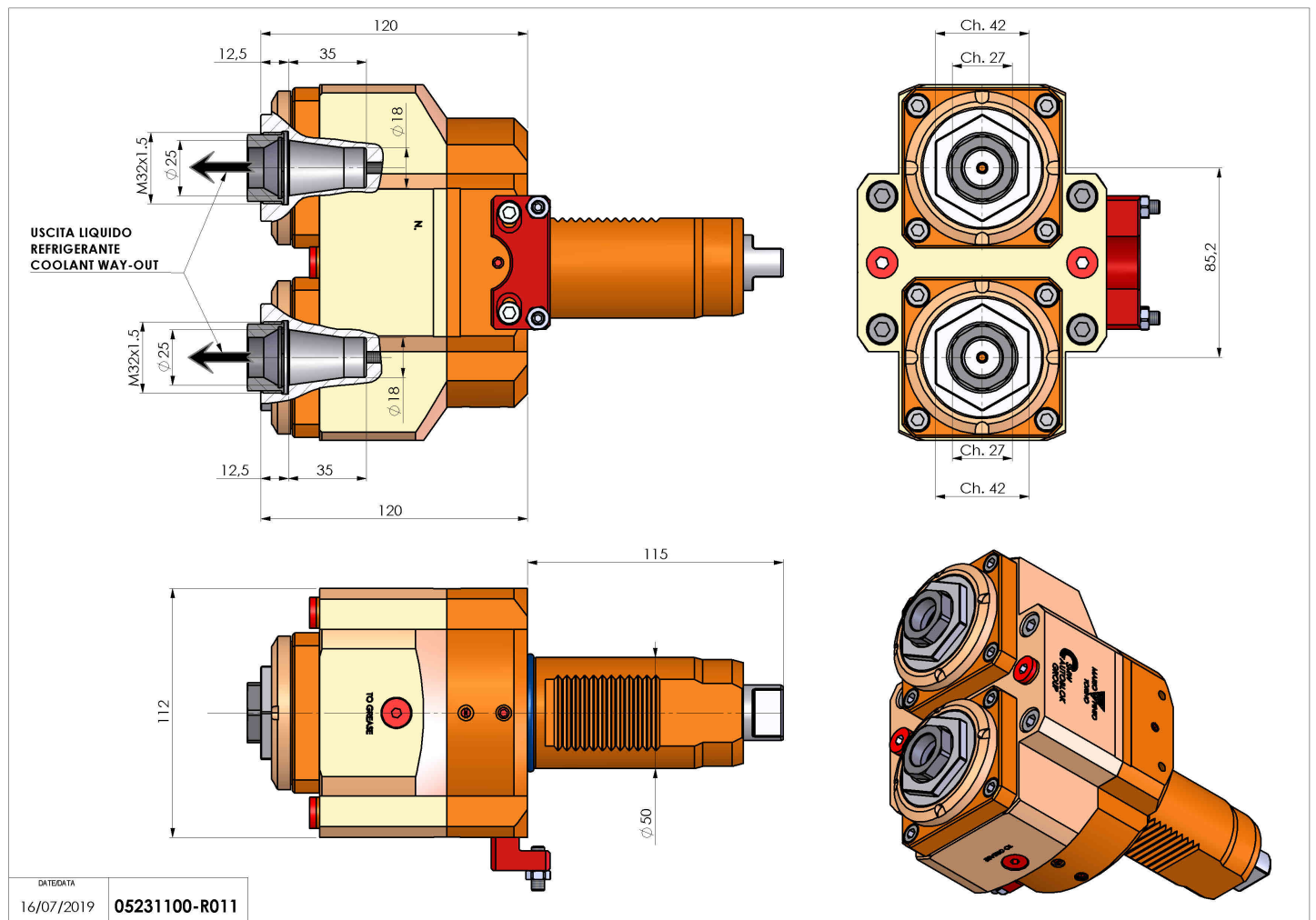

DATE/GATE 16/07/2019 05231100-R011

Subject to technical changes