

# 05230900 - LT-A VDI50 ER40F H100

Type	LT-A Tool holder angle 90°
Mounting	VDI 50
Tool output	Collet nut ER 40 F - internal nut
Coolant	External coolant
Direction of rotation	r1 ↻ r2 ↻
Max speed [rpm]	6000
Max torque [Nm]	100
Ratio	1:1
H [mm]	100
Accessories	N.A.
Notes	N.A.
Mounting tips	N.A.

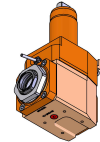

**ATTENTION: CHECK THE ORIENTATION OF THE VDI TEETH**

Always check live tool dimensions on the turret

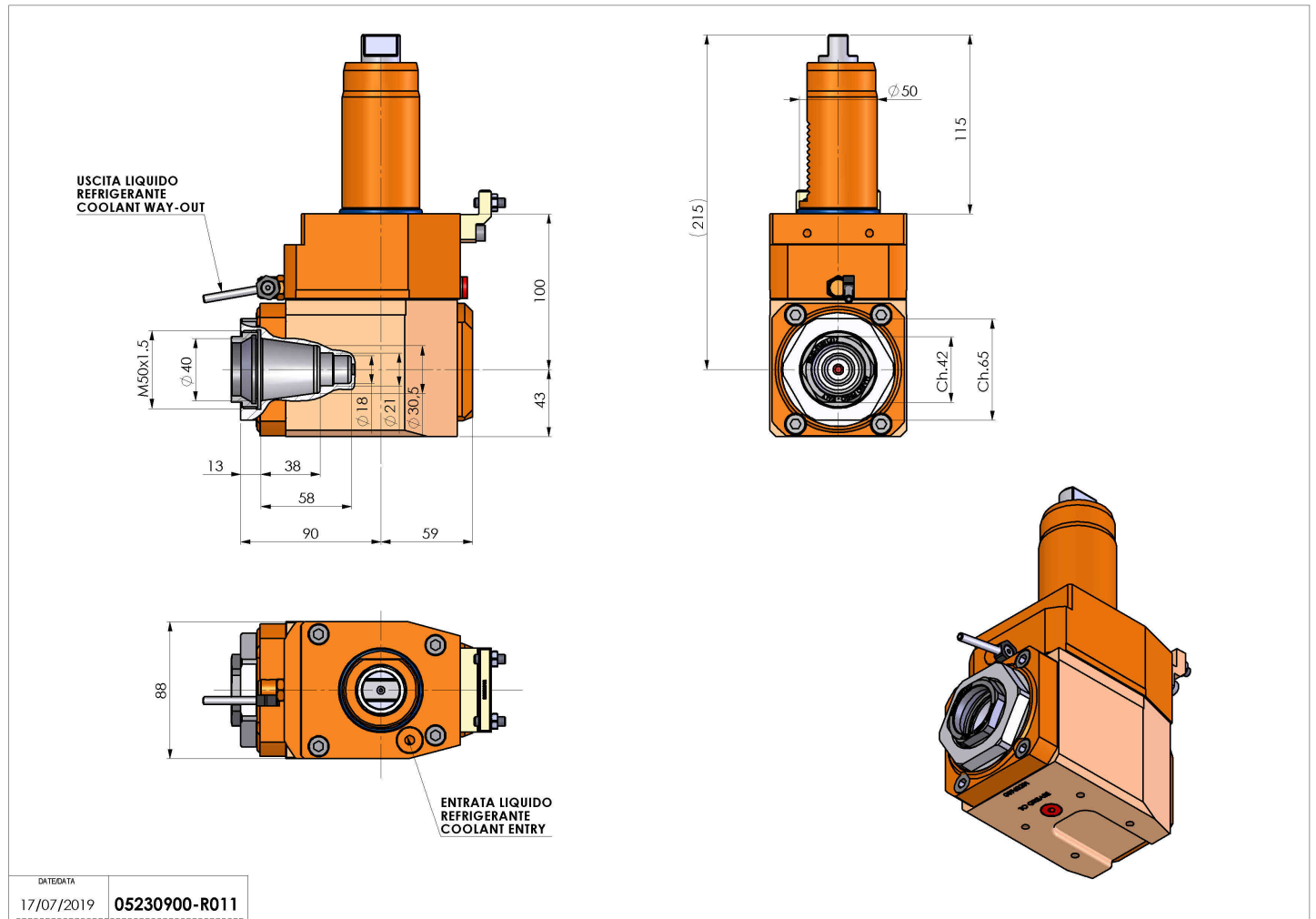

DATE/ATA	17/07/2019	05230900-R011
----------	------------	---------------

Subject to technical changes