

05229300 - LT-S VDI30 DIN138-16 H69 5480

Type	LT-S Tool holder straight
Mounting	VDI 30
Tool output	Shell-Mill DIN138 16
Coolant	External coolant
Direction of rotation	r1 ↻ r2 ↻
Max speed [rpm]	6000
Max torque [Nm]	40
Ratio	1:1
H [mm]	69
Accessories	N.A.
Notes	N.A.
Mounting tips	Disk-/star-type right and left turret

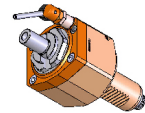

ATTENTION: CHECK THE ORIENTATION OF THE VDI TEETH

Always check live tool dimensions on the turret

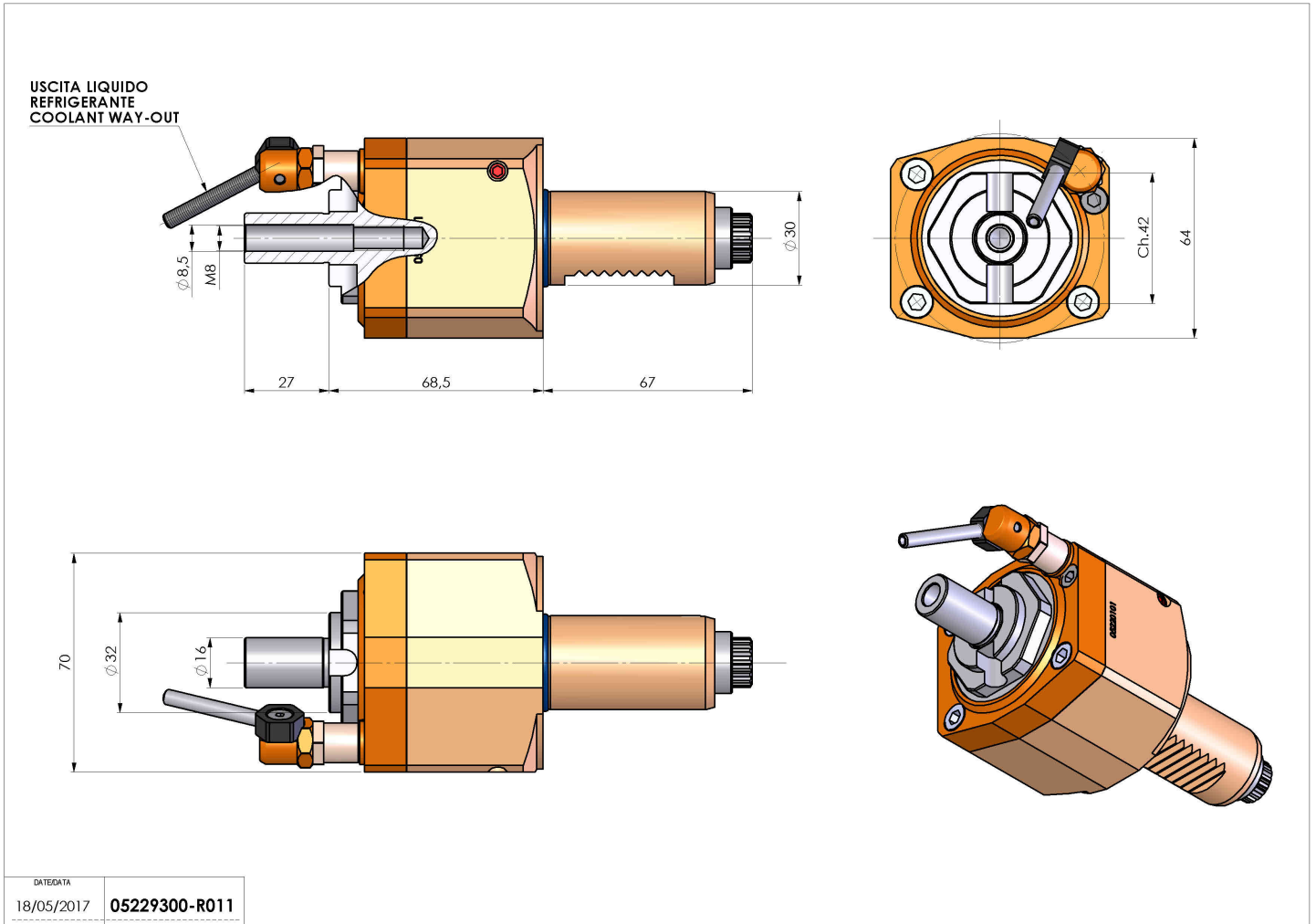

Subject to technical changes