

05229200 - LT-T VDI30 ER16F R-L H97-166SA

Type	LT-T Tool holder tiltable
Mounting	VDI 30
Tool output	Collet nut ER 16 F - internal nut
Coolant	External coolant
Direction of rotation	r1 ↻ r2 ↻
Max speed [rpm]	6000
Max torque [Nm]	10
Ratio	1:1
H [mm]	97-166
Accessories	N.A.
Notes	N.A.
Mounting tips	N.A.

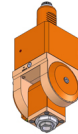

ATTENTION: CHECK THE ORIENTATION OF THE VDI TEETH

Always check live tool dimensions on the turret

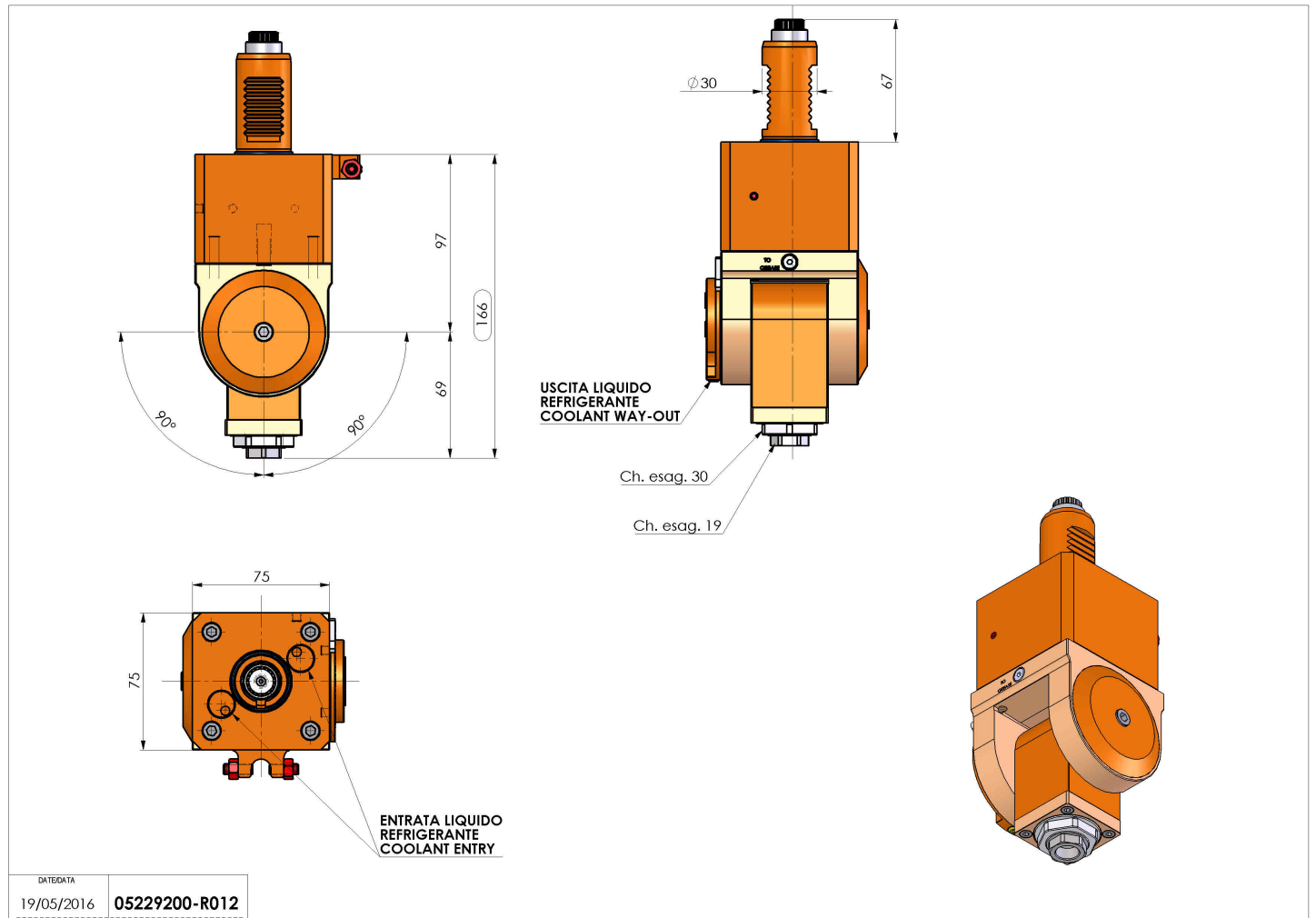

DATE/DATE
19/05/2016 05229200-R012

Subject to technical changes