

05228000 - LT-A2 VDI40 ER25 1:1 5480SA

Type	LT-A2 H Tool holder angle 90° double horizontal
Mounting	VDI 40
Tool output	Collet nut ER 25
Coolant	External coolant
Direction of rotation	r1 r2
Max speed [rpm]	3000
Ratio	1:1
H [mm]	63,5-103,5
H1 [mm]	27
Accessories	N.A.
Notes	N.A.
Mounting tips	N.A.

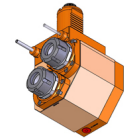

ATTENTION: CHECK THE ORIENTATION OF THE VDI TEETH

Always check live tool dimensions on the turret

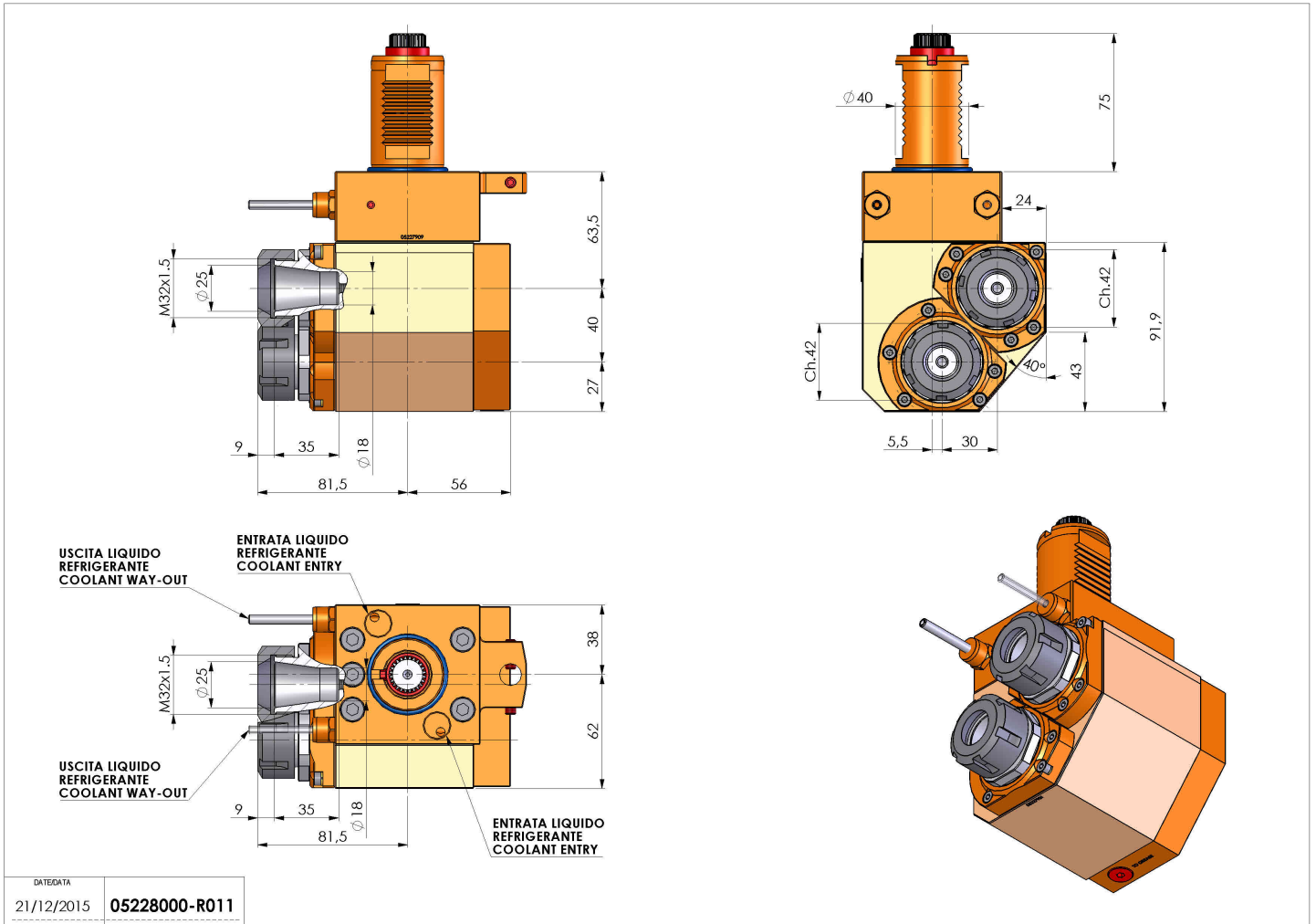

DATE/GATE	21/12/2015	05228000-R011
-----------	------------	---------------

Subject to technical changes