

05227600 - LT-A ST65VDI40 C16 H105 Y 5480

| | |
|----------------------------|------------------------------|
| Type | LT-A ST Slotting tool 90° |
| Mounting | VDI 40 |
| Tool output | Tool diameter 16 |
| Coolant | External coolant |
| Max speed [rpm] | 500 |
| Max torque [Nm] | 17,5 |
| Ratio | 1:1 |
| Y axis adjustment | SI |
| Feed pushing [N] | 1000 |
| Stroke [mm] | 65 |
| Work stroke [mm] | 60 |
| Y axis adjust. [mm] | ±0,4 |
| H [mm] | 105 |
| Accessories | N.A. |
| Notes | N.A. |
| Mounting tips | N.A. |

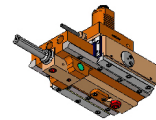

ATTENTION: CHECK THE ORIENTATION OF THE VDI TEETH

Always check live tool dimensions on the turret

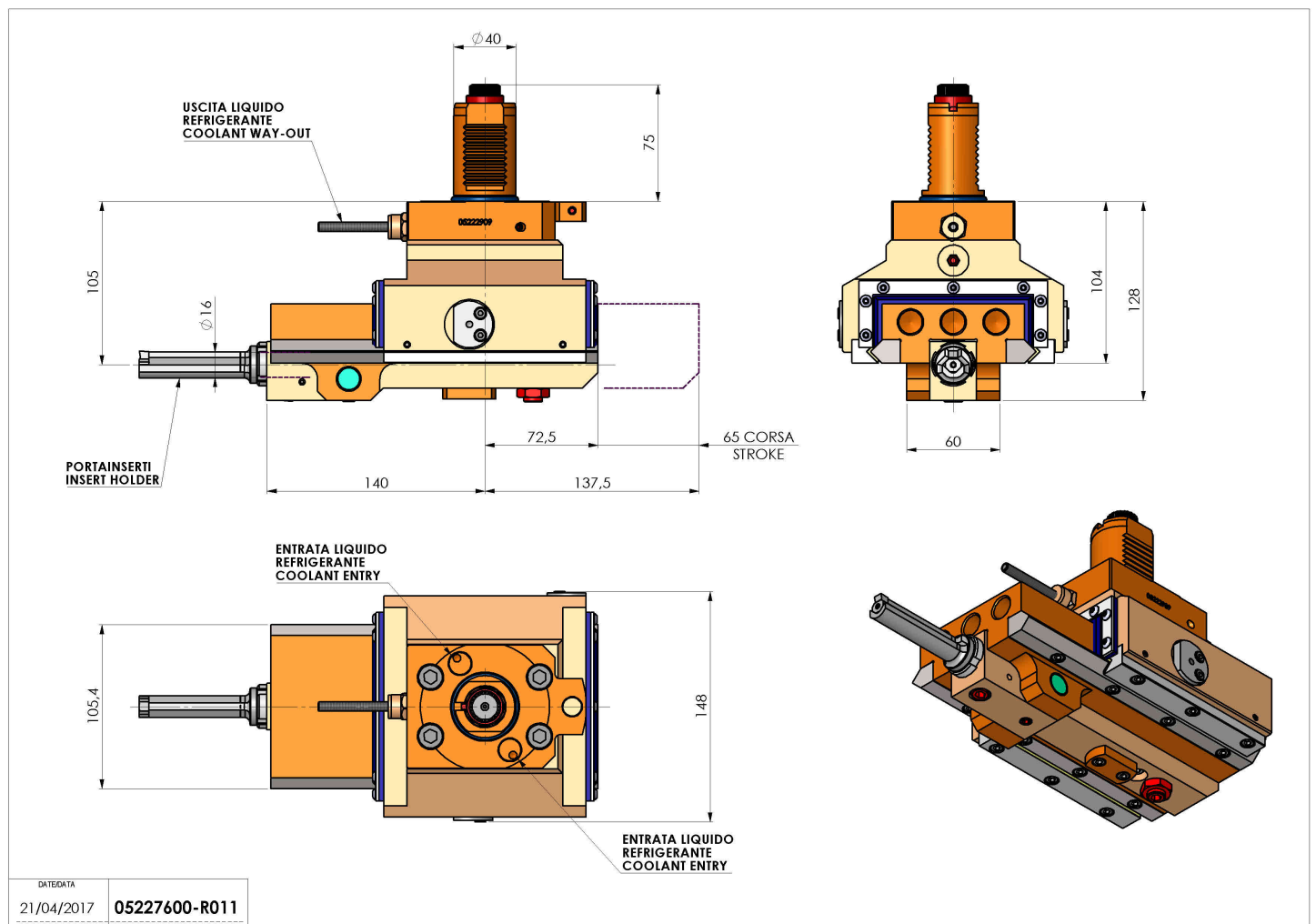

Subject to technical changes