

05225200 - LT-S2R VDI50 HSK40 I60 H118

Type	LT-S2 Tool holder double straight
Mounting	VDI 50
Tool output	Quick Change HSK40
Coolant	External coolant
Direction of rotation	
Max speed [rpm]	in r1=6000 / out r2=6000 r3=3000
Max torque [Nm]	in r1=60 / out r2=60 r3=120
Ratio	1:1 / 2:1
H [mm]	118
Accessories	N.A.
Notes	N.A.
Mounting tips	N.A.

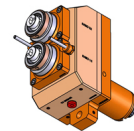

ATTENTION: CHECK THE ORIENTATION OF THE VDI TEETH

Always check live tool dimensions on the turret

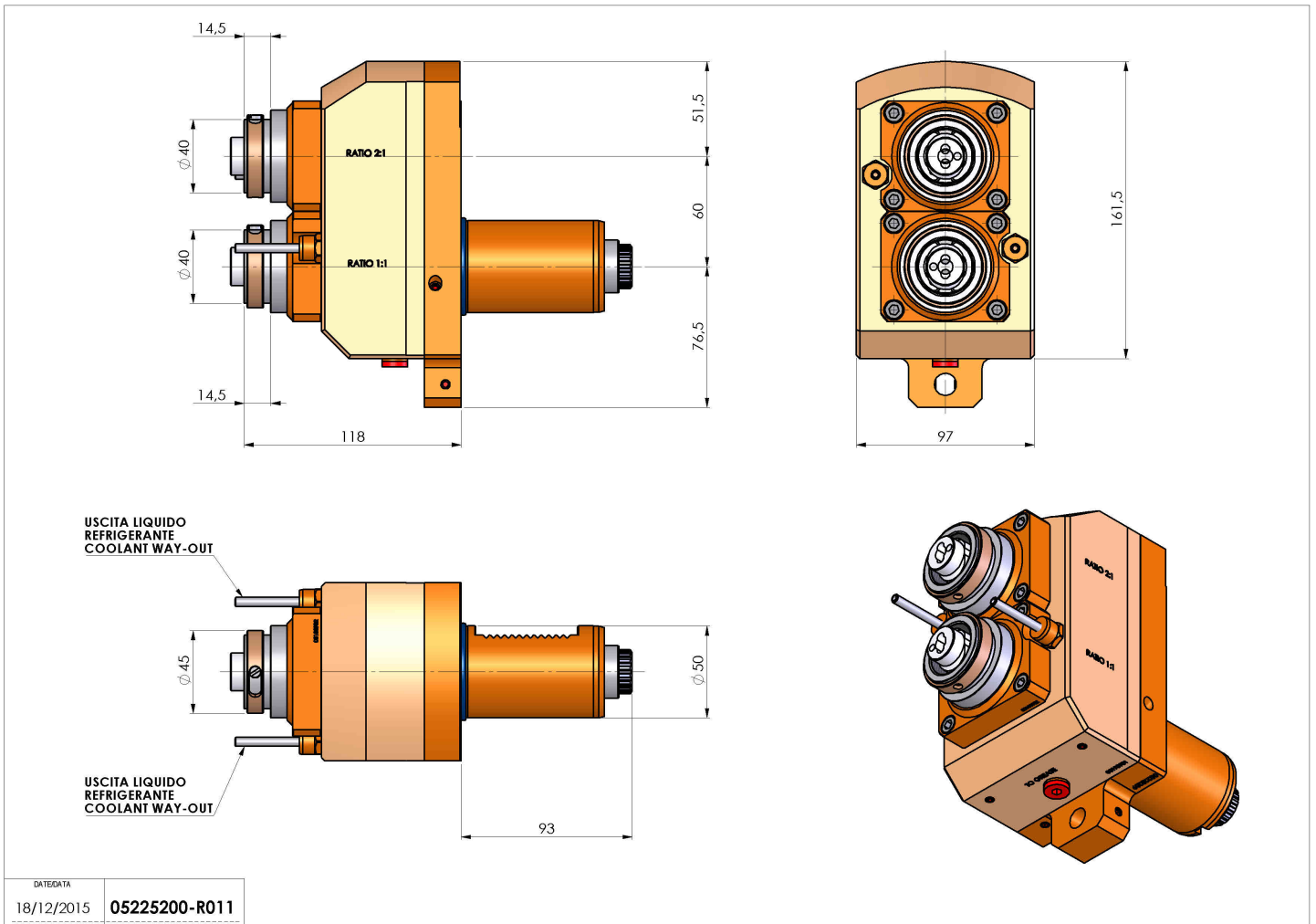

DATE/GATA	18/12/2015
PART NUMBER	05225200-R011

Subject to technical changes