

## 05179400 - LT-S VDI60 ER40F OFS75 RF 2:1 H110

Type	LT-S OFS Tool holder straight offset
Mounting	VDI 60
Tool output	Collet nut ER 40 F - internal nut
Coolant	Internal coolant
Offset [mm]	75
Direction of rotation	r1 ↻ r2 ↻
Max speed [rpm]	in 4000 / out 2000
Max torque [Nm]	in 100 / out 200
Ratio	2:1
H [mm]	110
Accessories	N.A.
Notes	N.A.
Mounting tips	N.A.

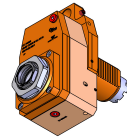

**ATTENTION: CHECK THE ORIENTATION OF THE VDI TEETH**

Always check live tool dimensions on the turret

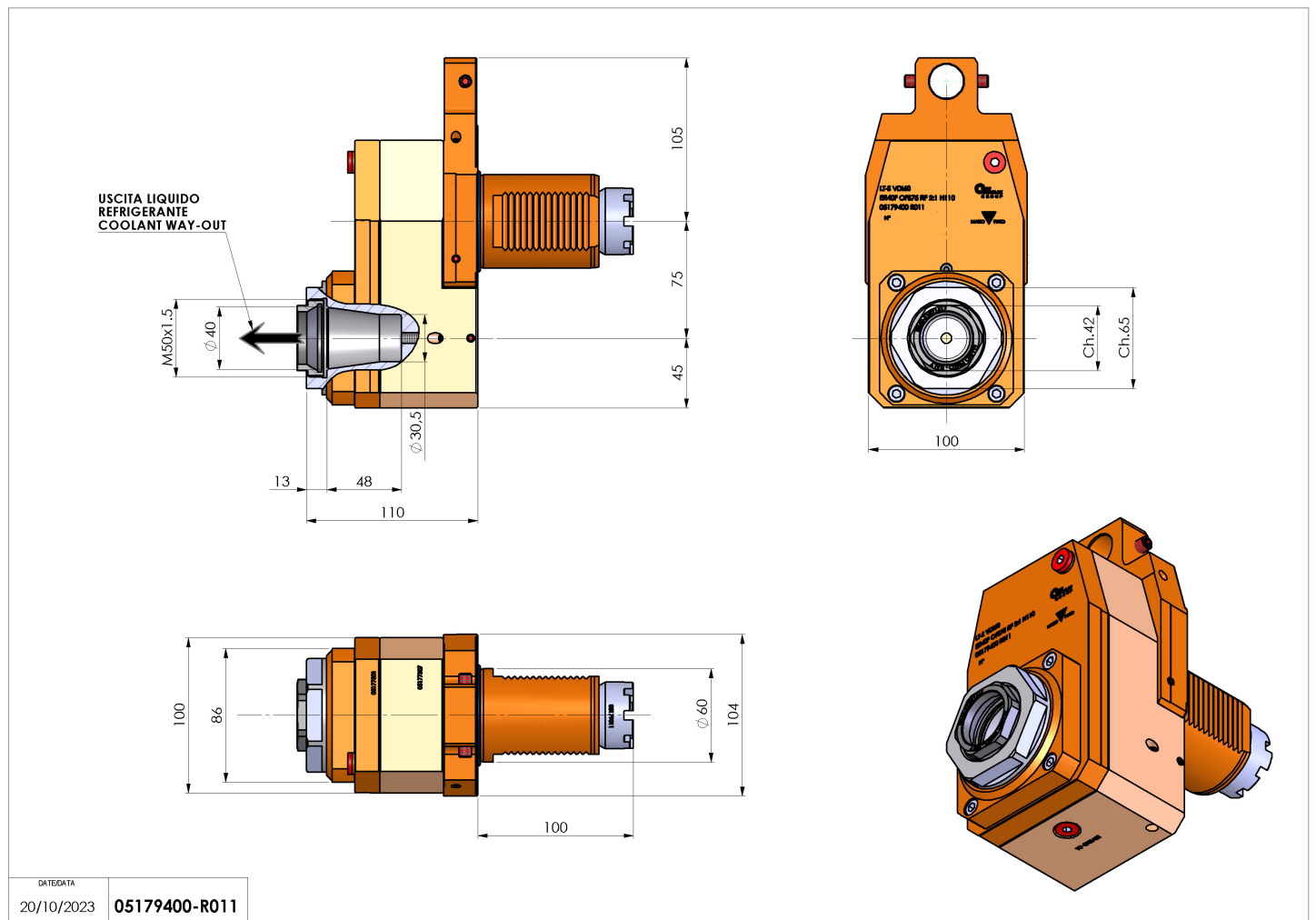

DATE/DATE  
20/10/2023 05179400-R011

Subject to technical changes