



05178200 - LT-S VDI30 ER25-F H60 BA

Type	LT-S Tool holder straight
Mounting	VDI 30
Tool output	Collet nut ER 25 F - internal nut
Coolant	External coolant
Direction of rotation	r1  r2 
Max speed [rpm]	6000
Max torque [Nm]	30
Ratio	1:1
H [mm]	59,5
Accessories	
Notes	N.A.
Mounting tips	Right and left disk-type turret

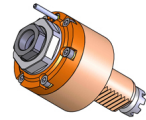

ATTENTION: CHECK THE ORIENTATION OF THE VDI TEETH

Always check live tool dimensions on the turret

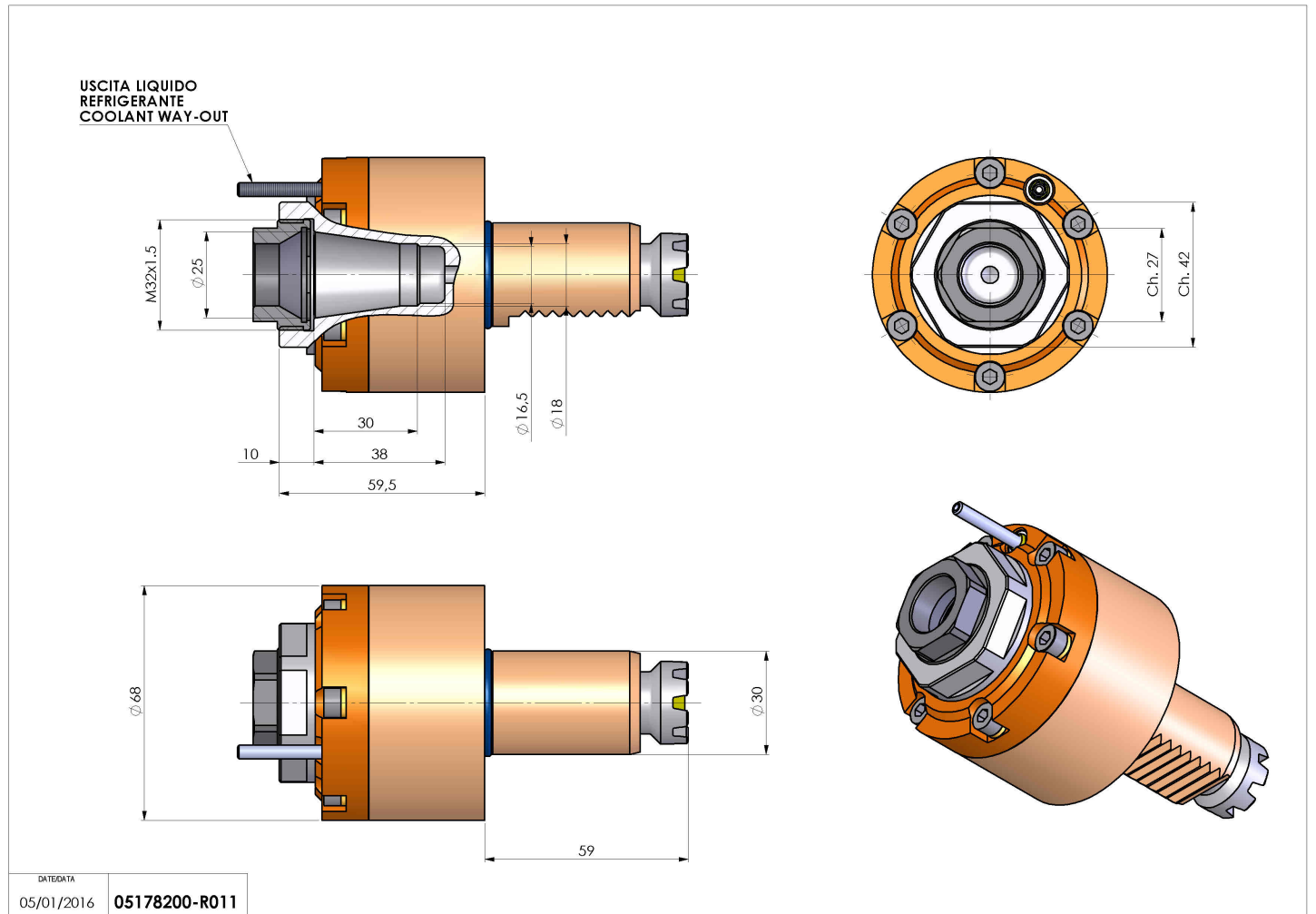

Subject to technical changes