

05178100 - LT-A VDI30 ER25F H78RF OF L BA

Type	LT-A OFS Tool holder offset angle 90°
Mounting	VDI 30
Tool output	Collet nut ER 25 F - internal nut
Coolant	Internal coolant
Direction of rotation	r1 ↻ r2 ↻
Max speed [rpm]	6000
Max torque [Nm]	25
Ratio	1:1
H [mm]	78
H1 [mm]	32,5
Max pressure [bar]	20
Accessories	N.A.
Notes	N.A.
Mounting tips	Verify VDI position betw. turret and live tool

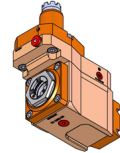

ATTENTION: CHECK THE ORIENTATION OF THE VDI TEETH

Always check live tool dimensions on the turret

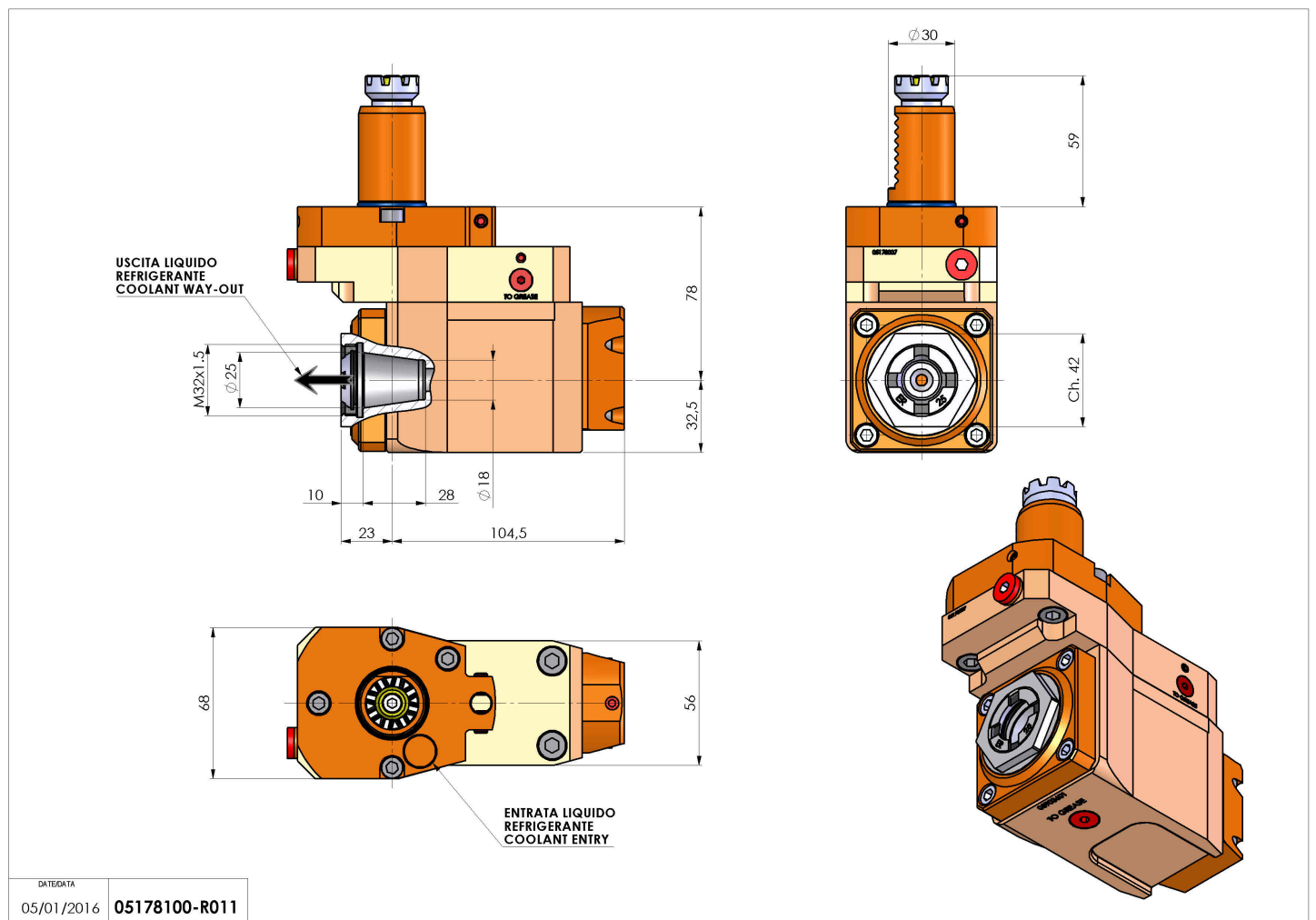

DATE/DATE	05/01/2016
	05178100-R011

Subject to technical changes