

# 05173200 - LT-S VDI30 DIN138-16 H67 BA

<b>Type</b>	LT-S Tool holder straight
<b>Mounting</b>	VDI 30
<b>Tool output</b>	Shell-Mill DIN138 16
<b>Coolant</b>	External coolant
<b>Direction of rotation</b>	r1  r2
<b>Max speed [rpm]</b>	6000
<b>Max torque [Nm]</b>	30
<b>Ratio</b>	1:1
<b>H [mm]</b>	67
<b>Accessories</b>	
<b>Notes</b>	Cannot be mounted near an offset angular
<b>Mounting tips</b>	Cannot be mounted near an angular offset

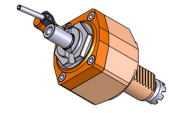

**ATTENTION: CHECK THE ORIENTATION OF THE VDI TEETH**

Always check live tool dimensions on the turret

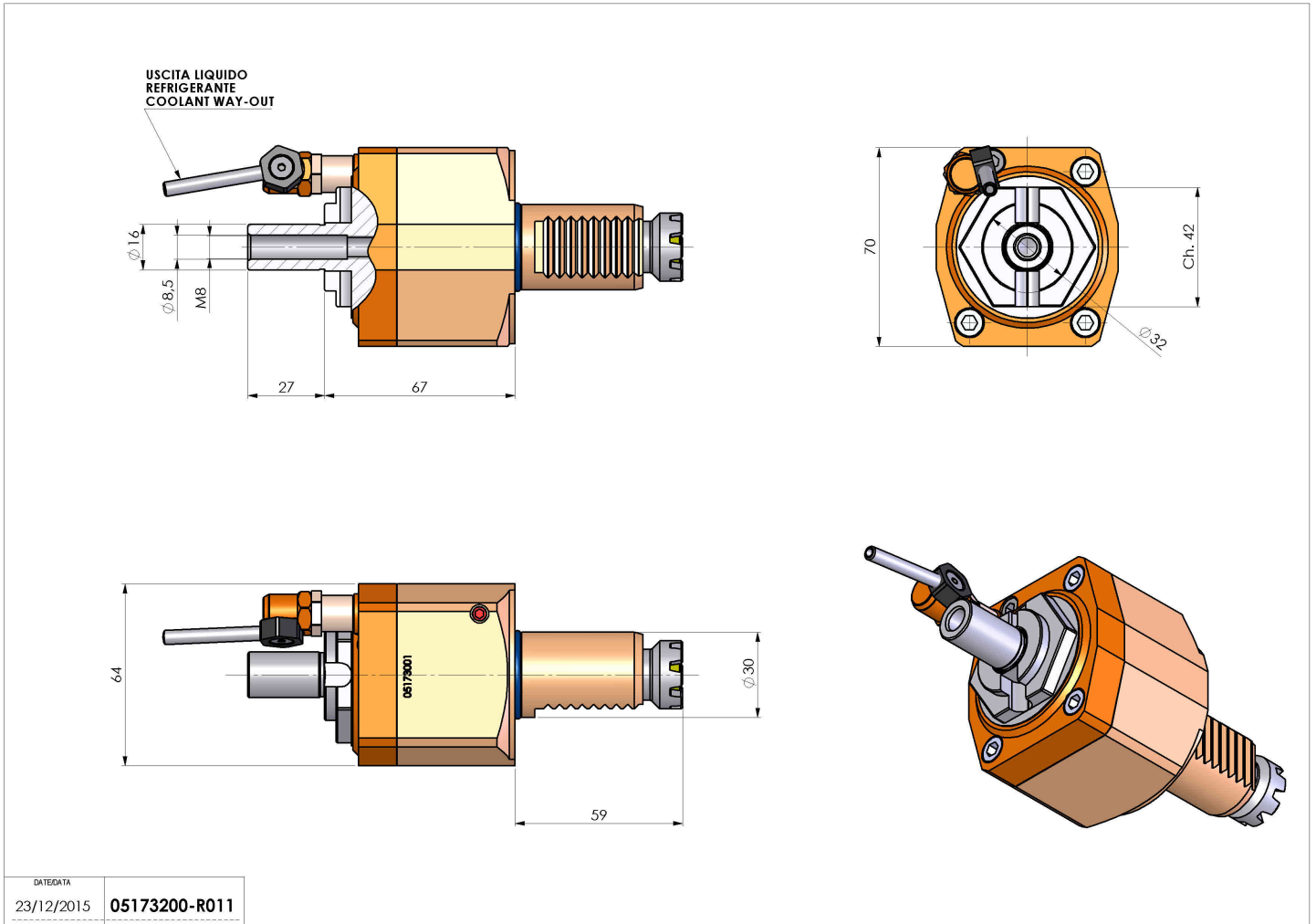

DATE/DATE	23/12/2015
05173200-R011	

Subject to technical changes