

05168800 - LT-A D55 ER25 LR 1:2 RF H125

| | |
|------------------------------|-------------------------------|
| Type | LT-A Tool holder angle 90° |
| Mounting | CYLINDRICAL SHANK 55 |
| Tool output | Collet nut ER 25 |
| Coolant | Internal coolant |
| Direction of rotation | r1 r2 |
| Max speed [rpm] | in 6000 / out 12000 |
| Max torque [Nm] | in 60 / out 30 |
| Ratio | 1:2 |
| H [mm] | 125 |
| H1 [mm] | 32,5 |
| Max pressure [bar] | 20 |
| Accessories | N.A. |
| Notes | N.A. |
| Mounting tips | N.A. |

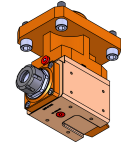

Always check live tool dimensions on the turret

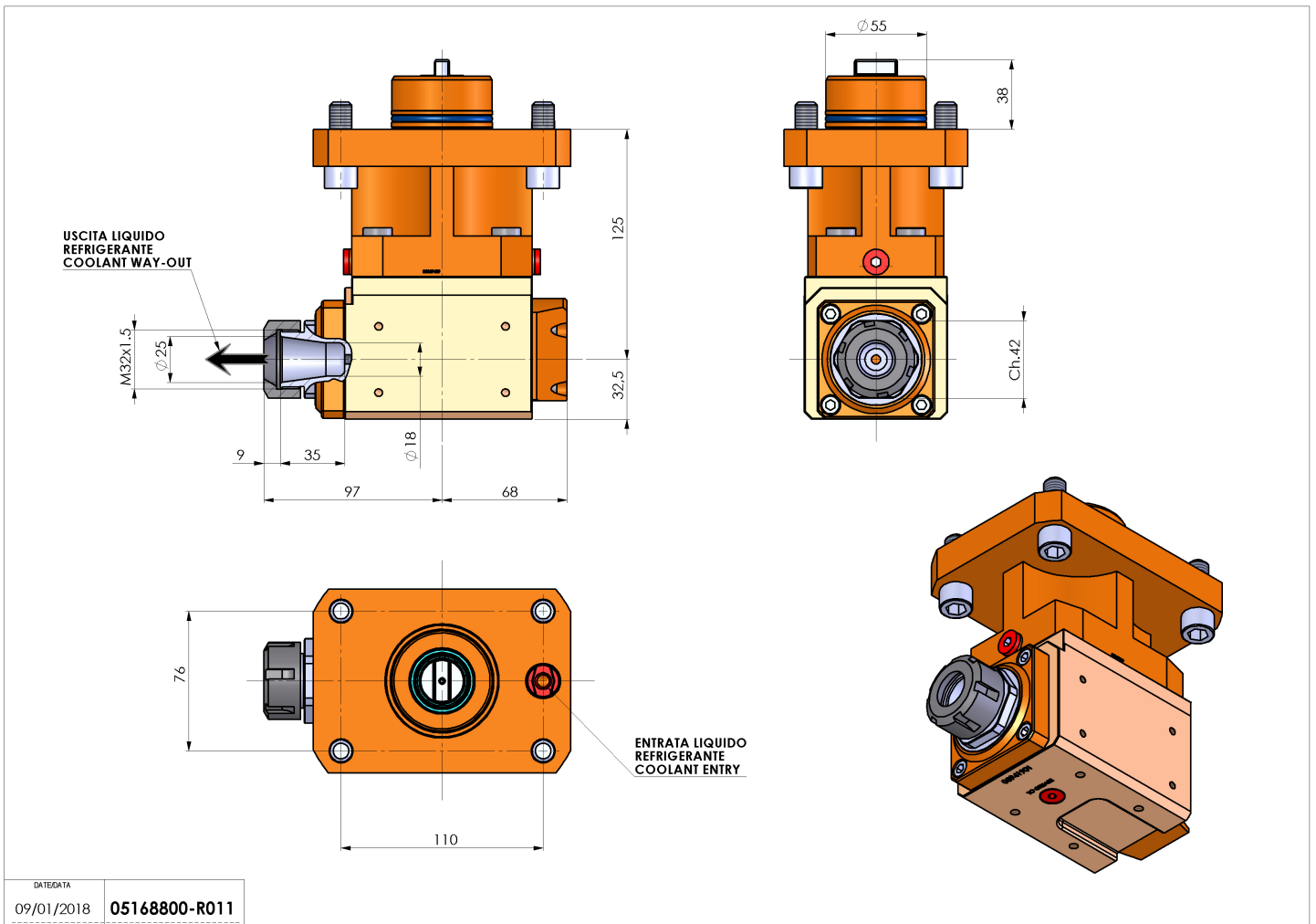

| | |
|------------|----------------------|
| DATE/DATE | |
| 09/01/2018 | 05168800-R011 |

Subject to technical changes