

05167600 - LT-A D44 ER25 LR 1:2 H60

Type	LT-A Tool holder angle 90°
Mounting	CYLINDRICAL SHANK 44
Tool output	Collet nut ER 25
Coolant	External coolant
Direction of rotation	r1 ↻ r2 ↻
Max speed [rpm]	in 6000 / out 12000
Max torque [Nm]	in 10 / out 5
Ratio	1:2
H [mm]	60
H1 [mm]	27
Accessories	N.A.
Notes	N.A.
Mounting tips	N.A.

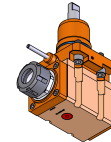

Always check live tool dimensions on the turret

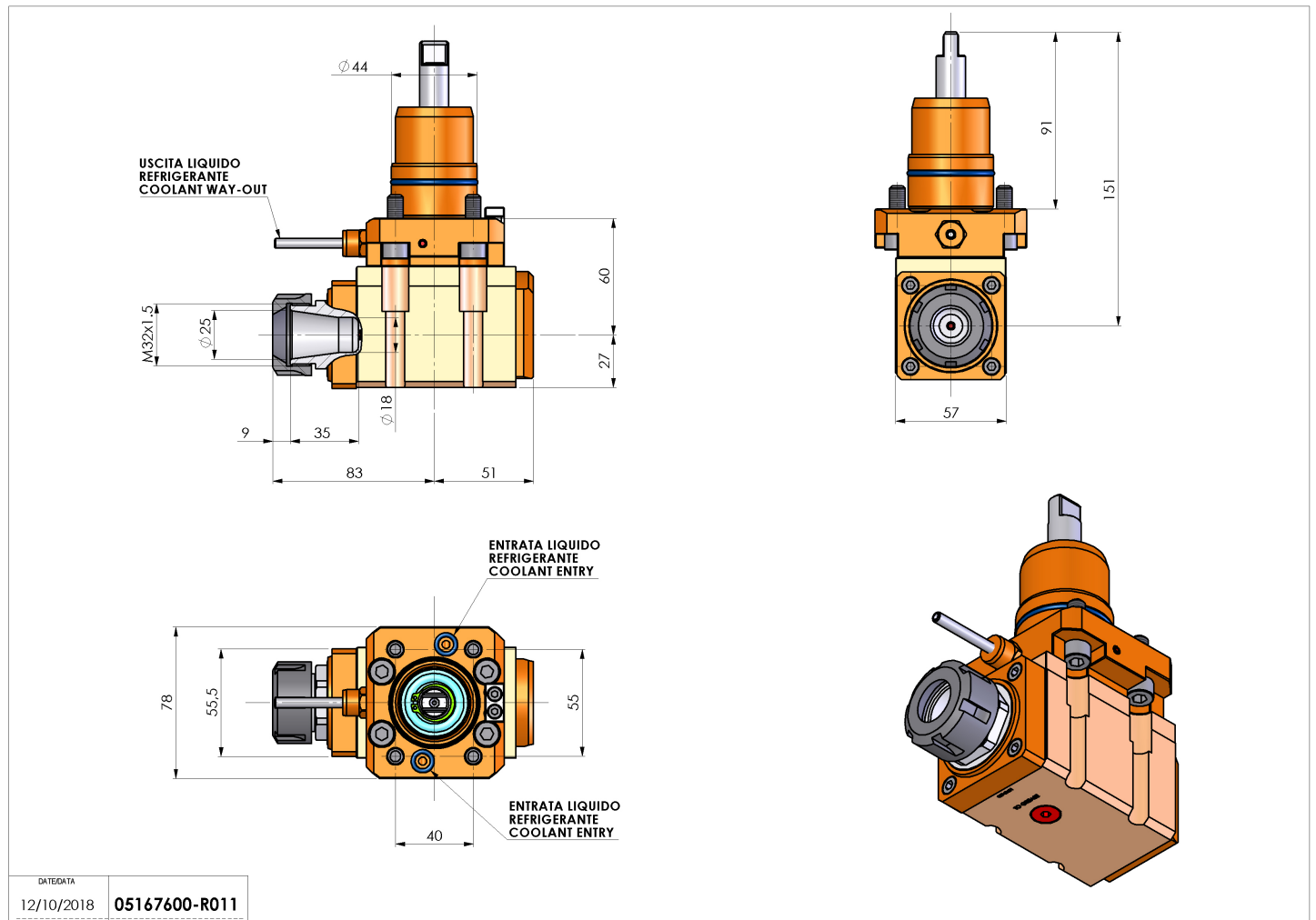

DATE/DATE	
12/10/2018	05167600-R011

Subject to technical changes