

05162200 - LT-S D55 ER32 HRF OFS100 H118

Type	LT-S OFS Tool holder straight offset
Mounting	CYLINDRICAL SHANK 55
Tool output	Collet nut ER 32
Coolant	HRF Internal coolant
Offset [mm]	100
Direction of rotation	r1 ↻ r2 ↻
Max speed [rpm]	6000
Max torque [Nm]	60
Ratio	1:1
H [mm]	118
Max pressure [bar]	80
Accessories	N.A.
Notes	N.A.
Mounting tips	N.A.

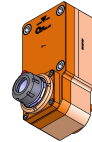

Always check live tool dimensions on the turret

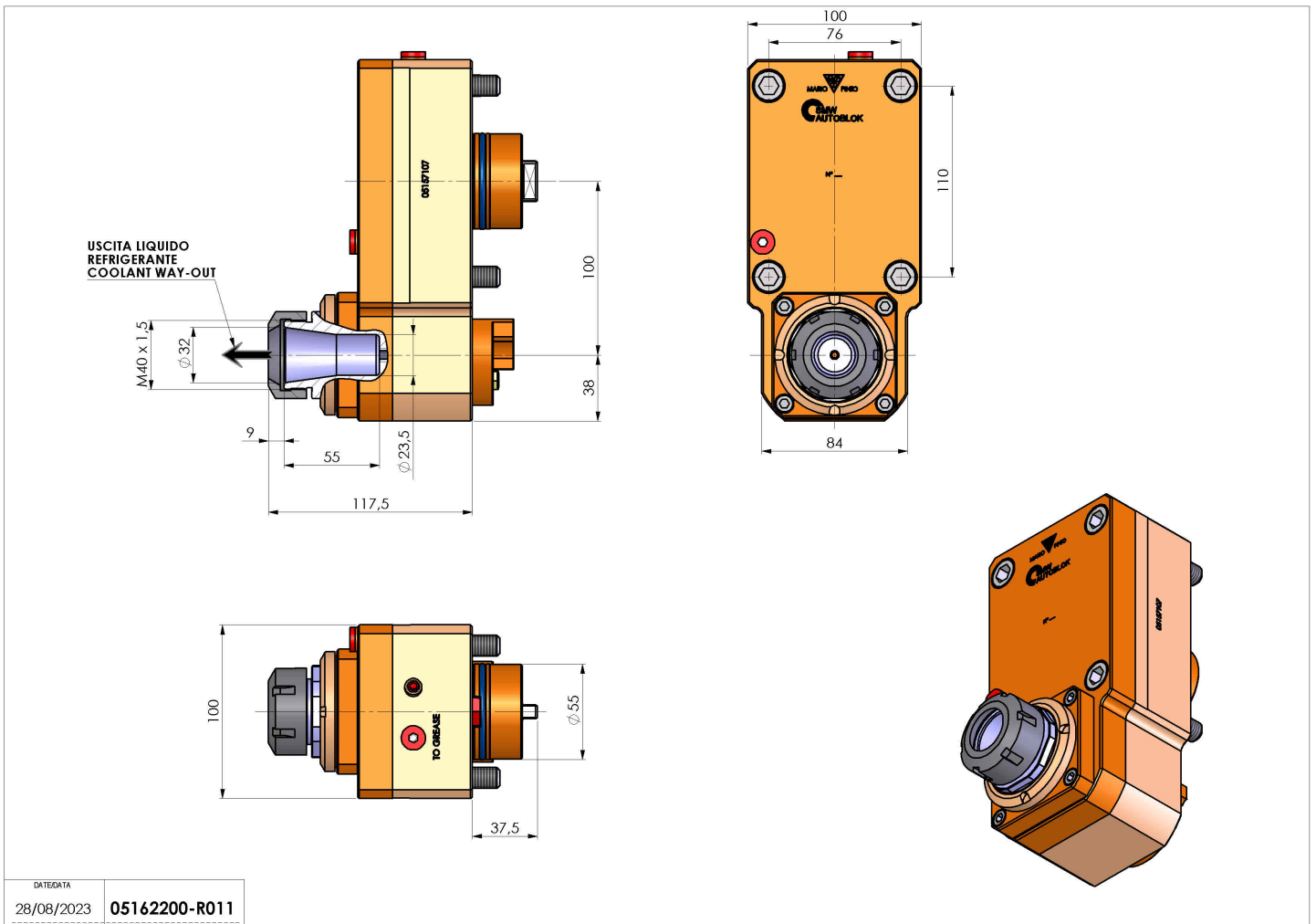

DATE/DATE	05162200-R011
28/08/2023	

Subject to technical changes