

05160800 - LT-A D35 ER20F 1:2 H60 MU

Type	LT-A Tool holder angle 90°
Mounting	CYLINDRICAL SHANK 35
Tool output	Collet nut ER 20 F - internal nut
Coolant	External coolant
Direction of rotation	r1 ↻ r2 ↻
Max speed [rpm]	in 6000 / out 12000
Max torque [Nm]	in 10 / out 5
Ratio	1:2
H [mm]	60
H1 [mm]	28
Accessories	N.A.
Notes	N.A.
Mounting tips	N.A.

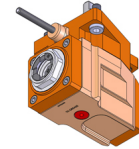

Always check live tool dimensions on the turret

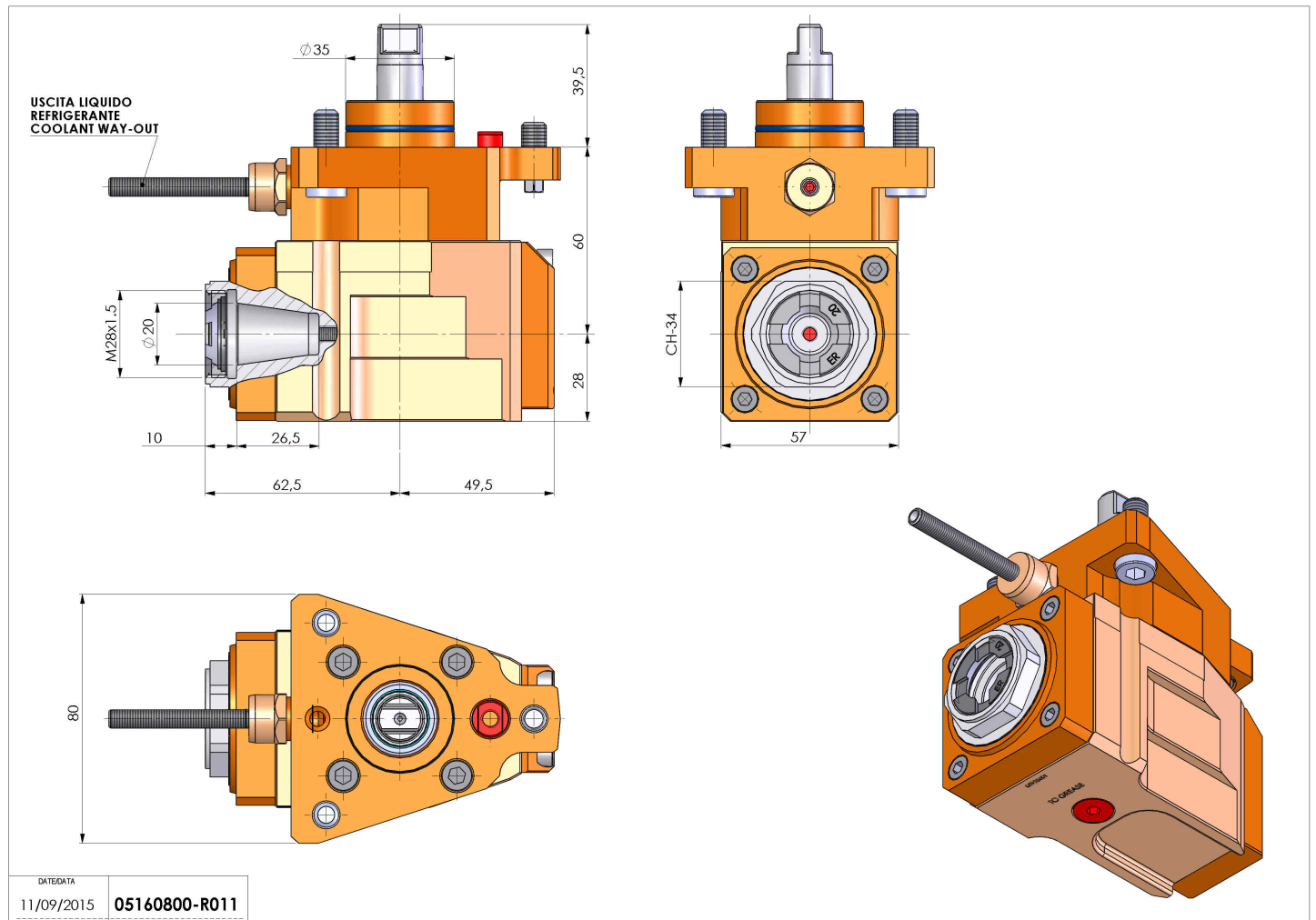

Subject to technical changes