

05158700 - LT-A D55 ER25 LR 1:2 H125 MU

Type	LT-A Tool holder angle 90°
Mounting	CYLINDRICAL SHANK 55
Tool output	Collet nut ER 25
Coolant	External coolant
Direction of rotation	r1 ↻ r2 ↻
Max speed [rpm]	in 6000 / out 12000
Max torque [Nm]	in 60 / out 30
Ratio	1:2
H [mm]	125
H1 [mm]	32,5
Accessories	N.A.
Notes	N.A.
Mounting tips	N.A.

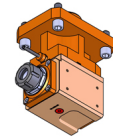

Always check live tool dimensions on the turret

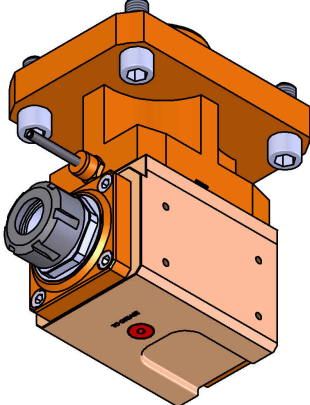
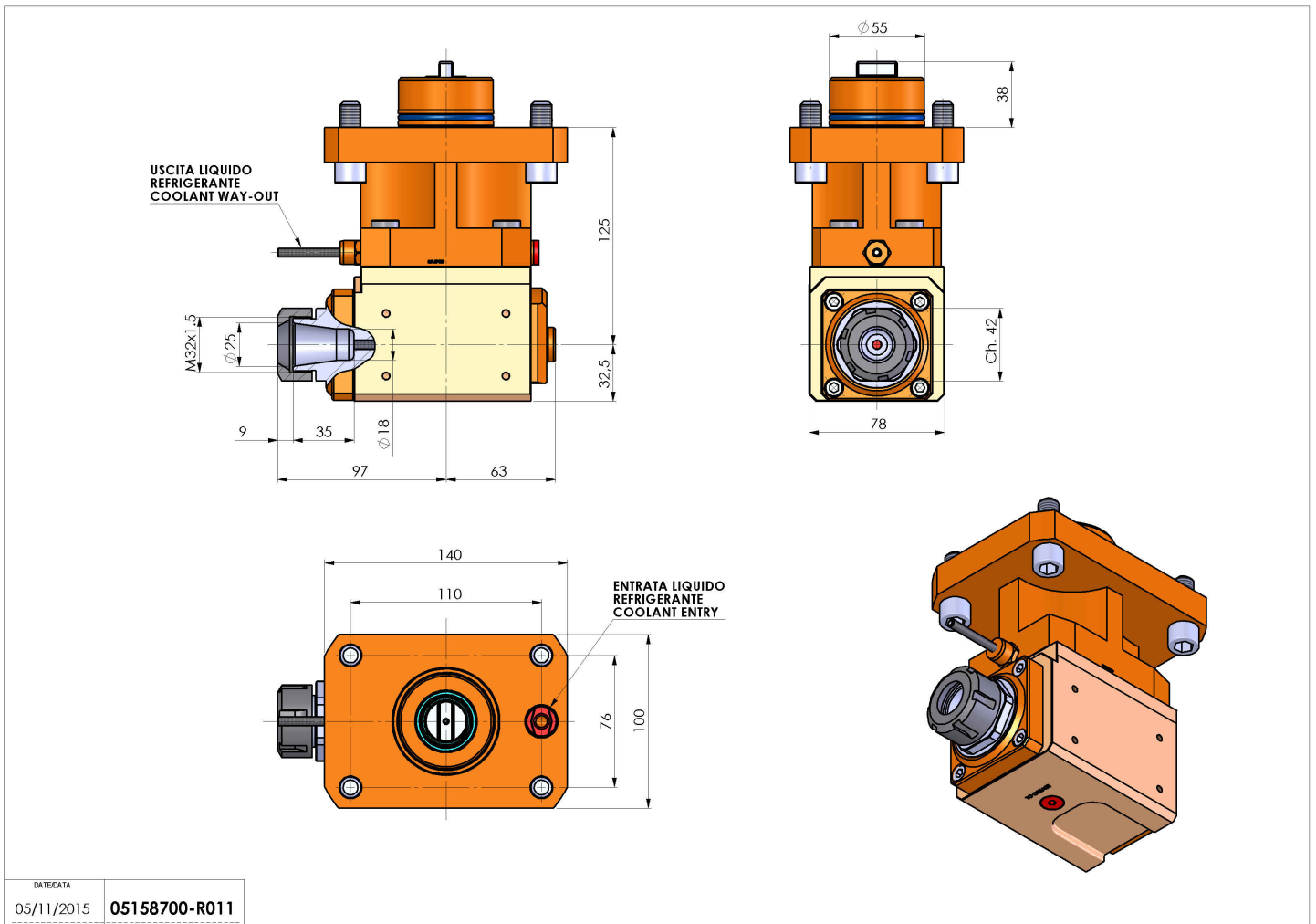

DATE/DATE	05/11/2015	05158700-R011
-----------	------------	---------------

Subject to technical changes