

05140000 - LT-S D88 ER32 OFS-100 H108 OW

Type	LT-S OFS Tool holder straight offset
Mounting	CYLINDRICAL SHANK 88
Tool output	Collet nut ER 32
Coolant	External coolant
Offset [mm]	100
Direction of rotation	r1 r2
Max speed [rpm]	6000
Max torque [Nm]	63
Ratio	1:1
H [mm]	108,5
Accessories	N.A.
Notes	N.A.
Mounting tips	Main spindle only

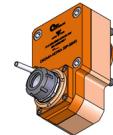

Always check live tool dimensions on the turret

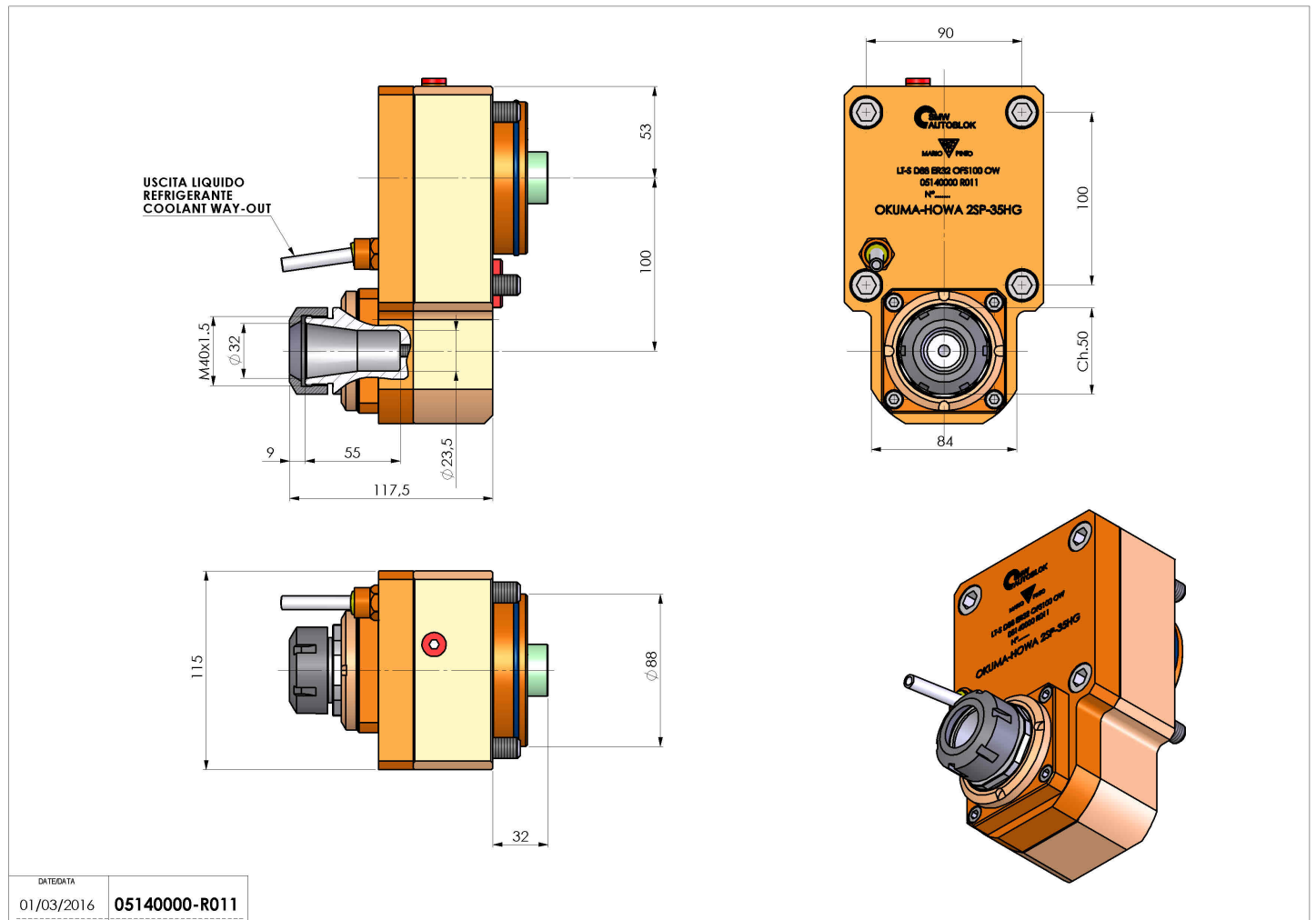

Subject to technical changes