

05128900 - LT-A ST35 BMT55 C12 H85

Type	LT-A ST Slotting tool 90°
Mounting	BMT 55
Tool output	Tool diameter 12
Coolant	External coolant
Max speed [rpm]	700
Max torque [Nm]	17.5
Ratio	1:1
Y axis adjustment	NO
Feed pushing [N]	700
Stroke [mm]	35
Work stroke [mm]	35
H [mm]	85
Accessories	N.A.
Notes	N.A.
Mounting tips	N.A.

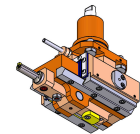

Always check live tool dimensions on the turret

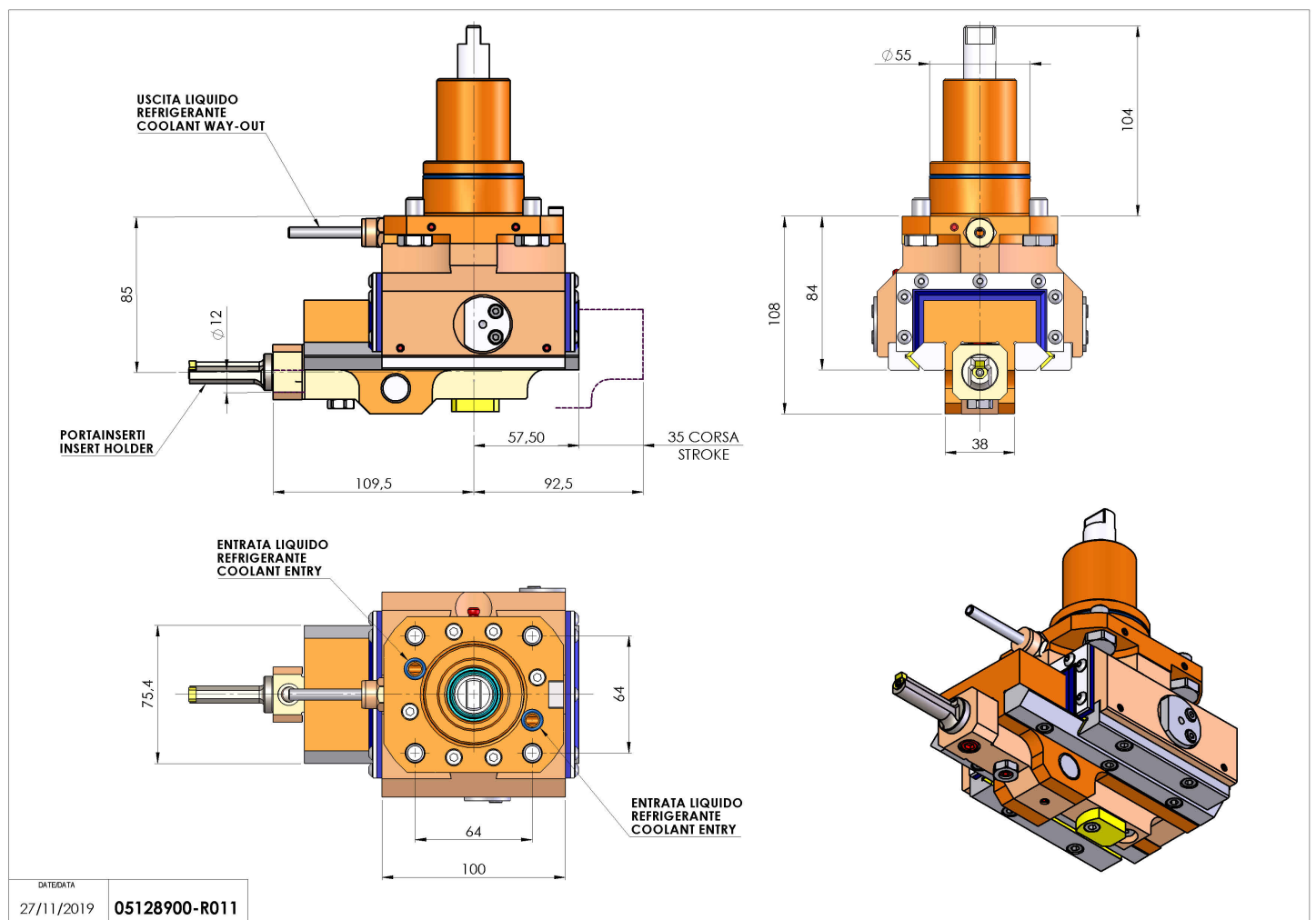

Subject to technical changes