

05127800 - LT-ABMT55ER25FRFOFS1:1.75H78DW

Type	LT-A OFS Tool holder offset angle 90°
Mounting	BMT 55
Tool output	Collet nut ER 25 F - internal nut
Coolant	Internal coolant
Direction of rotation	r1 ↻ r2 ↻
Max speed [rpm]	in 5700 / out 10000
Max torque [Nm]	in 25 / out 14
Ratio	1:1,75
H [mm]	78
H1 [mm]	32,5
Max pressure [bar]	20
Accessories	N.A.
Notes	N.A.
Mounting tips	Secondary spindle only

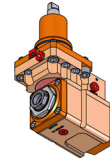

Always check live tool dimensions on the turret

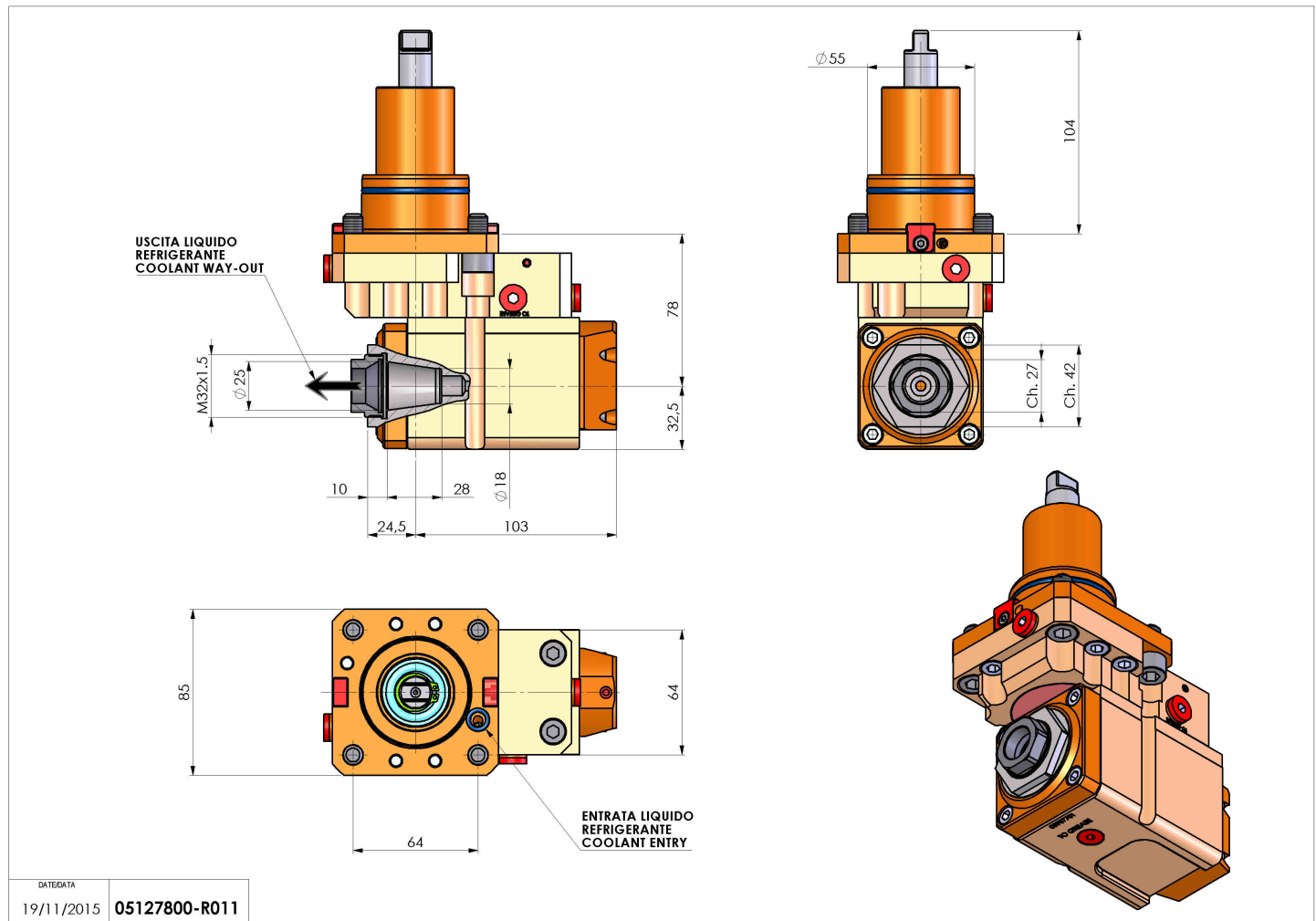

DATE/DATE	19/11/2015	05127800-R011
-----------	------------	---------------

Subject to technical changes