

05127600 - LT-A ST37.5 BMT55 C12 H90 DW

Type	LT-A ST Slotting tool 90°
Mounting	BMT 55
Tool output	Tool diameter 12
Coolant	External coolant
Max speed [rpm]	700
Max torque [Nm]	17,5
Ratio	1:1
Y axis adjustment	NO
Feed pushing [N]	1000
Stroke [mm]	37,5
Work stroke [mm]	32,5
H [mm]	90
Accessories	N.A.
Notes	N.A.
Mounting tips	N.A.

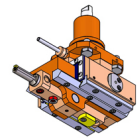

Always check live tool dimensions on the turret

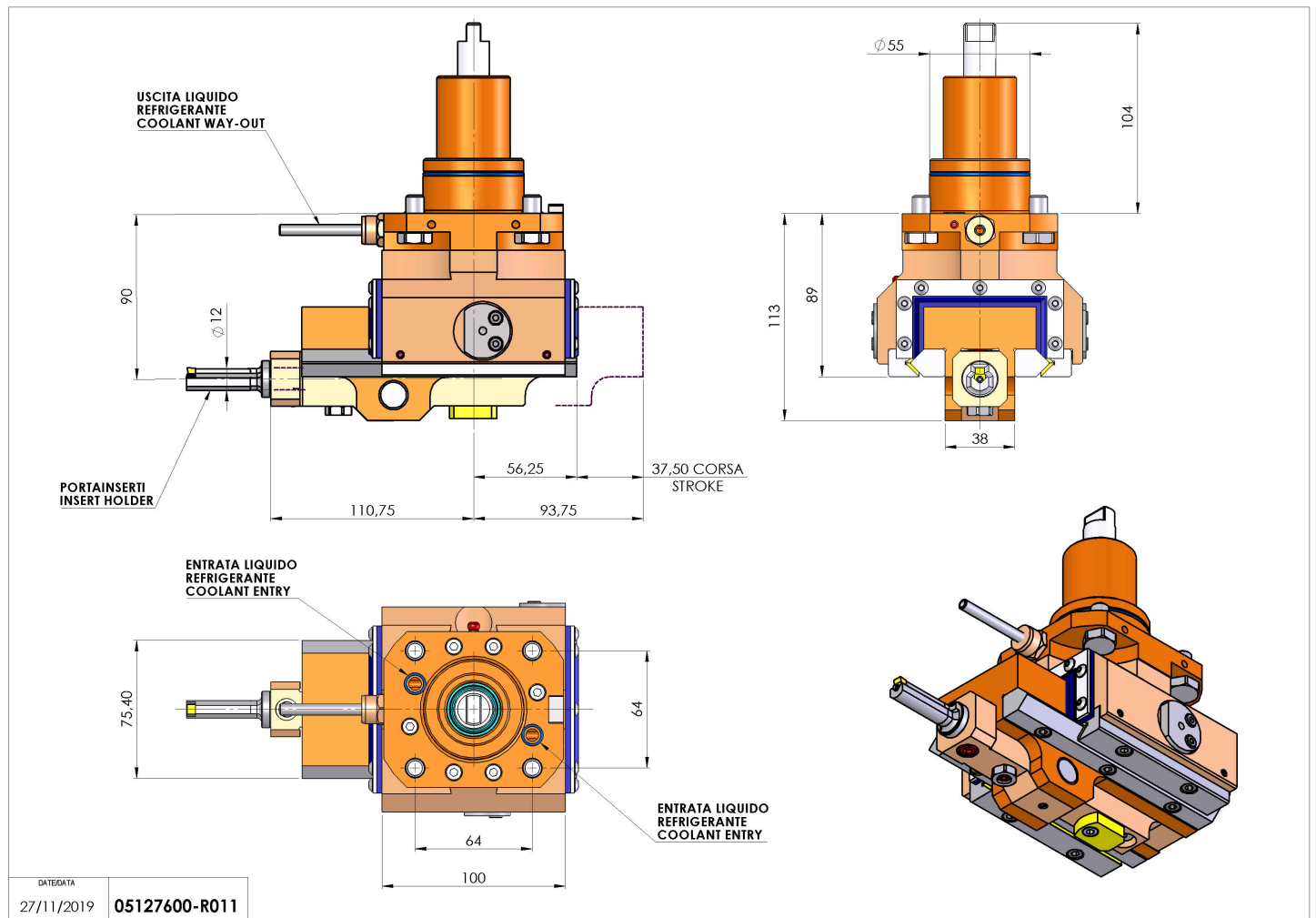

Subject to technical changes