

05125600 - LT-A BMT85 ISO40 OF RF H110 DW

Type	LT-A OFS Tool holder offset angle 90°
Mounting	BMT 85
Tool output	Quick Change ISO-BT40
Coolant	Internal coolant
Direction of rotation	r1 ↻ r2 ↻
Max speed [rpm]	4000
Max torque [Nm]	180
Ratio	1:1
H [mm]	110
H1 [mm]	52
Max pressure [bar]	20
Accessories	N.A.
Notes	N.A.
Mounting tips	N.A.

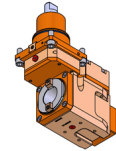

Always check live tool dimensions on the turret

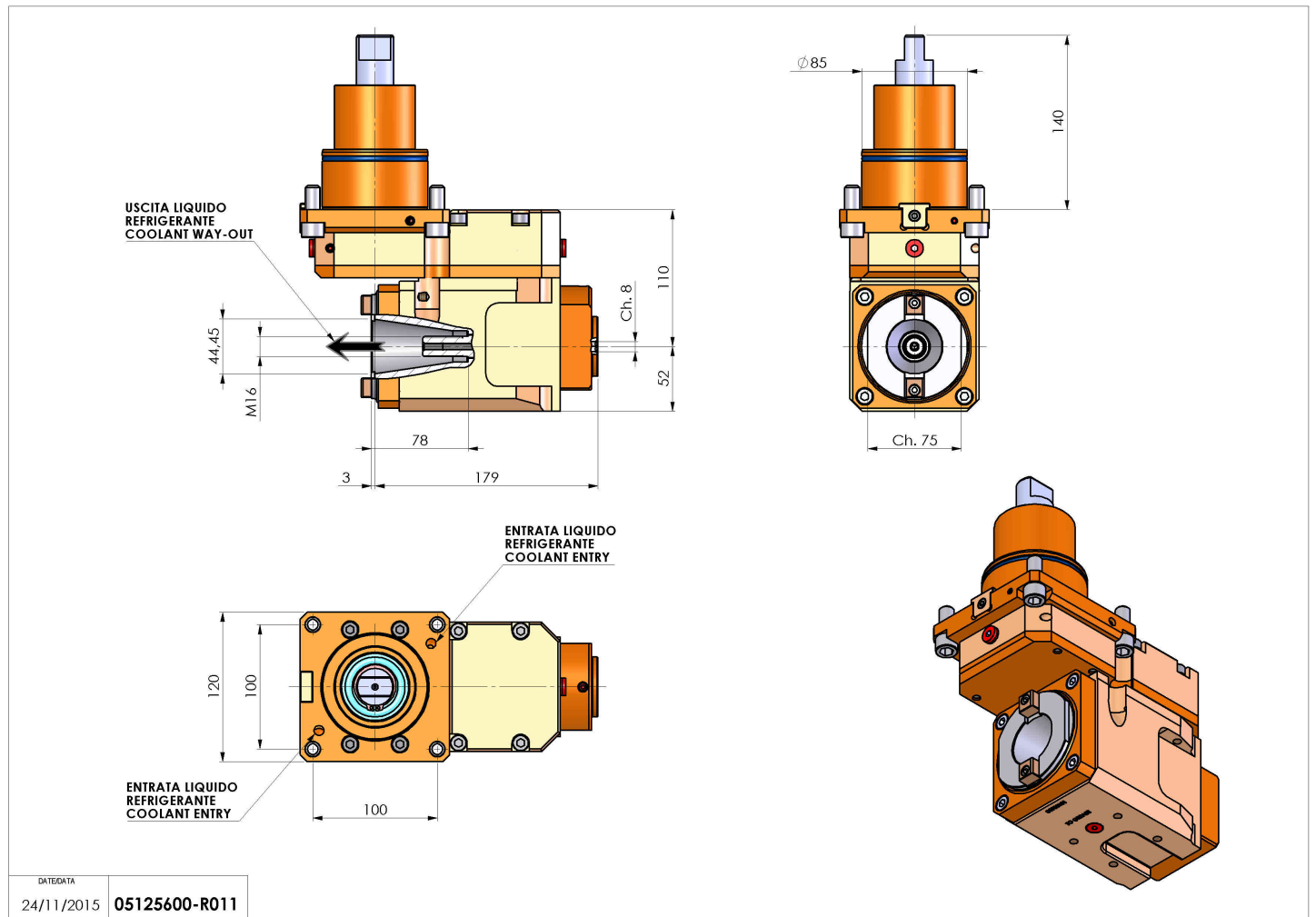

DATE/DATA
24/11/2015 05125600-R011

Subject to technical changes