

# 05100400 - LT-A BMT65 DIN-22 L-R H72 K-W

|                       |                               |
|-----------------------|-------------------------------|
| Type                  | LT-A<br>Tool holder angle 90° |
| Mounting              | BMT 65                        |
| Tool output           | Shell-Mill DIN138 22          |
| Coolant               | External coolant              |
| Direction of rotation | r1 ↻ r2 ↻                     |
| Max speed [rpm]       | 6000                          |
| Max torque [Nm]       | 63                            |
| Ratio                 | 1:1                           |
| H [mm]                | 72                            |
| H1 [mm]               | 38                            |
| Accessories           | N.A.                          |
| Notes                 | N.A.                          |
| Mounting tips         | N.A.                          |

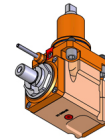

Always check live tool dimensions on the turret

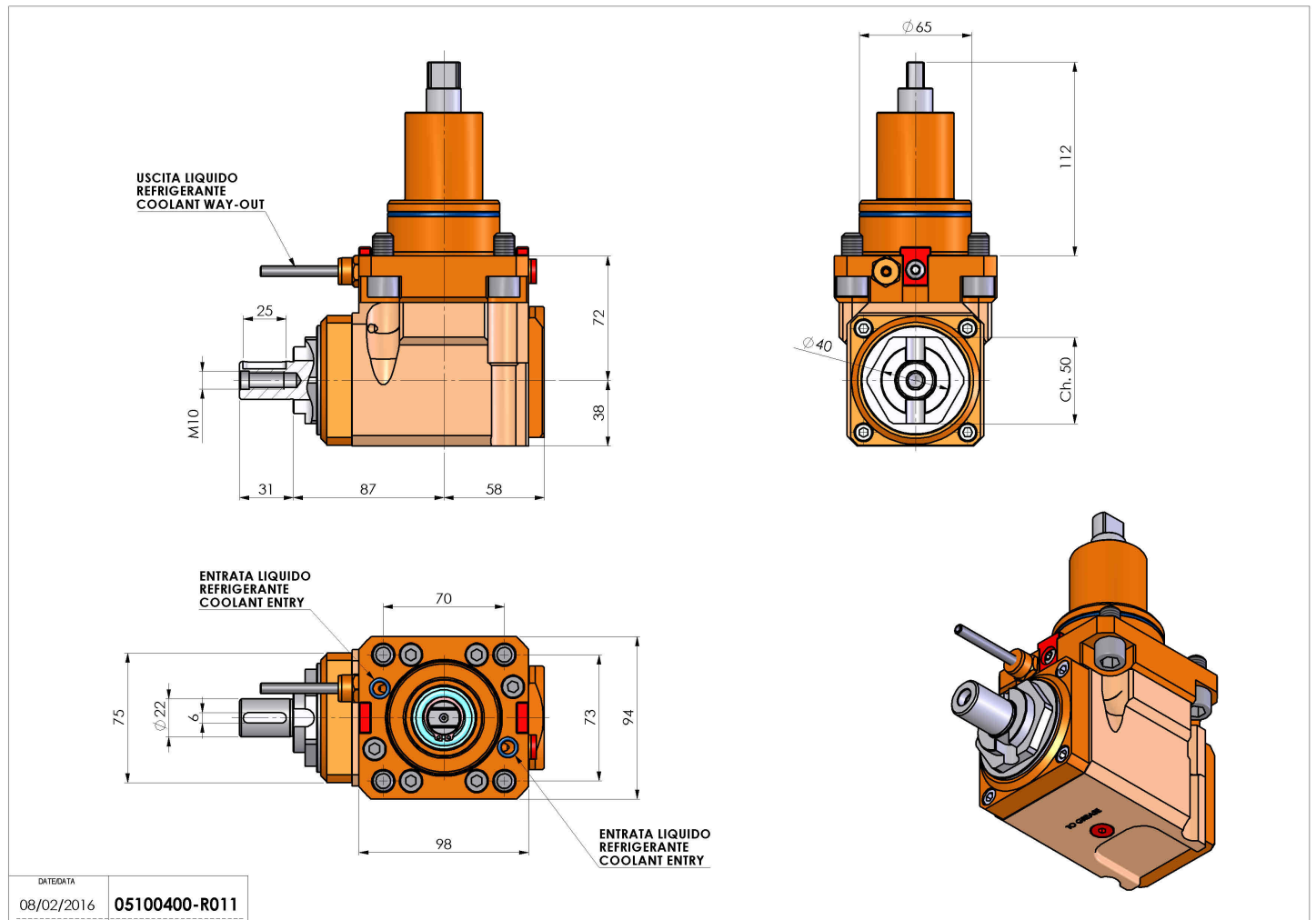

|           |               |
|-----------|---------------|
| DATE/DATE | 08/02/2016    |
|           | 05100400-R011 |

Subject to technical changes