

# 05077300 - LT-A45 D55 ER32F LR2:1H104BI

<b>Type</b>	LT-A-(a) Tool holder with fix angle (alpha)
<b>Mounting</b>	CYLINDRICAL SHANK 55
<b>Tool output</b>	Collet nut ER 32 F - internal nut
<b>Coolant</b>	External coolant
<b>Direction of rotation</b>	r1 ↻ r2 ↻
<b>Max speed [rpm]</b>	in 6000 / out 3000
<b>Max torque [Nm]</b>	in 40 / out 80
<b>Ratio</b>	2:1
<b>H [mm]</b>	104
<b>H1 [mm]</b>	123
<b>Accessories</b>	N.A.
<b>Notes</b>	N.A.
<b>Mounting tips</b>	Main and secondary spindle

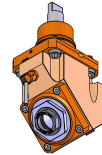

Always check live tool dimensions on the turret

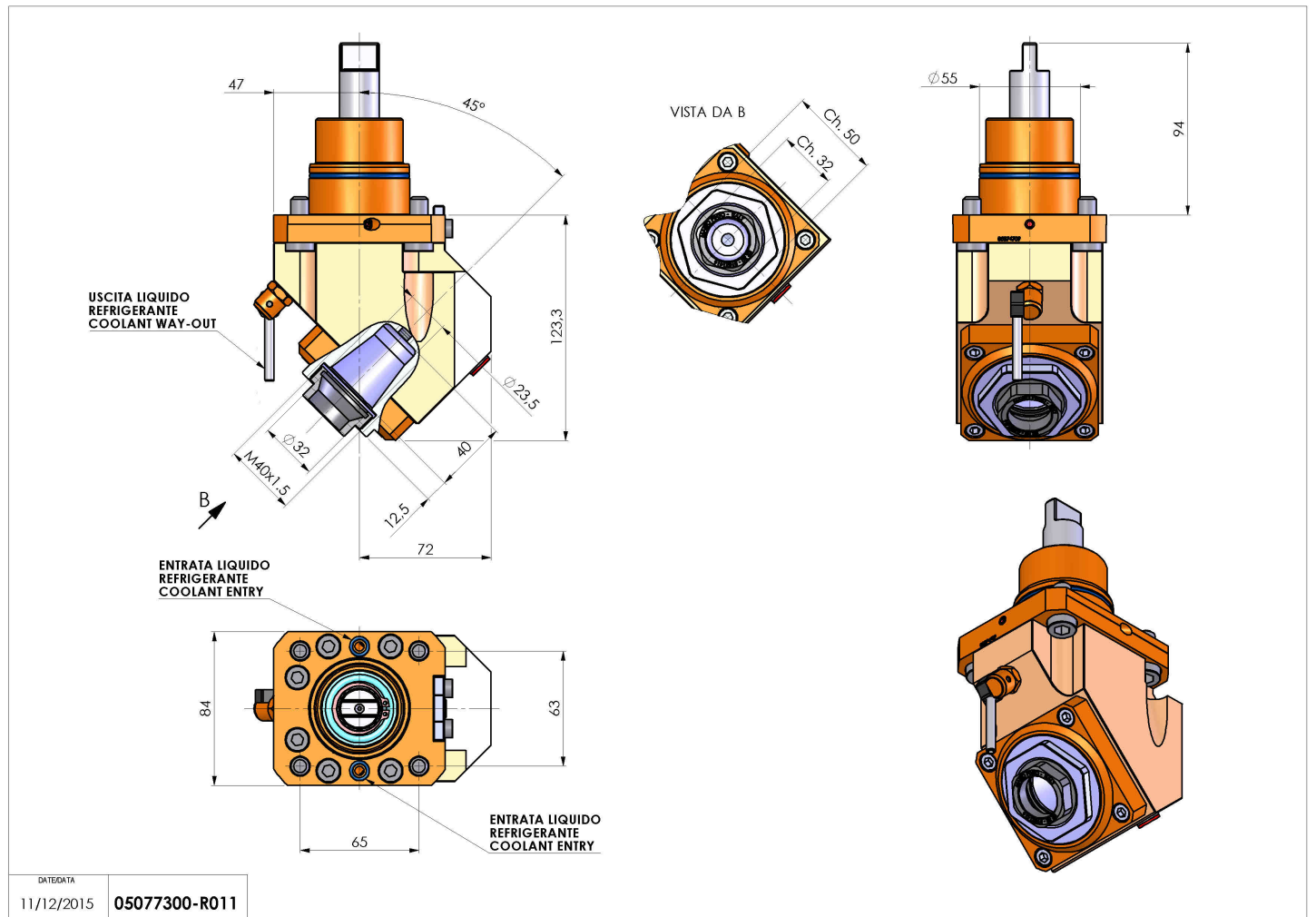

Subject to technical changes