

05076700 - LT-A D55 ER20F LR 1:2 H100 BI

Type	LT-A Tool holder angle 90°
Mounting	CYLINDRICAL SHANK 55
Tool output	Collet nut ER 20 F - internal nut
Coolant	External coolant
Direction of rotation	r1 ↻ r2 ↻
Max speed [rpm]	in 5000 / out 10000
Max torque [Nm]	in 50 / out 25
Ratio	1:2
H [mm]	100
H1 [mm]	27
Accessories	N.A.
Notes	N.A.
Mounting tips	Main and secondary spindle

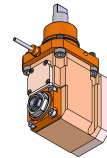

Always check live tool dimensions on the turret

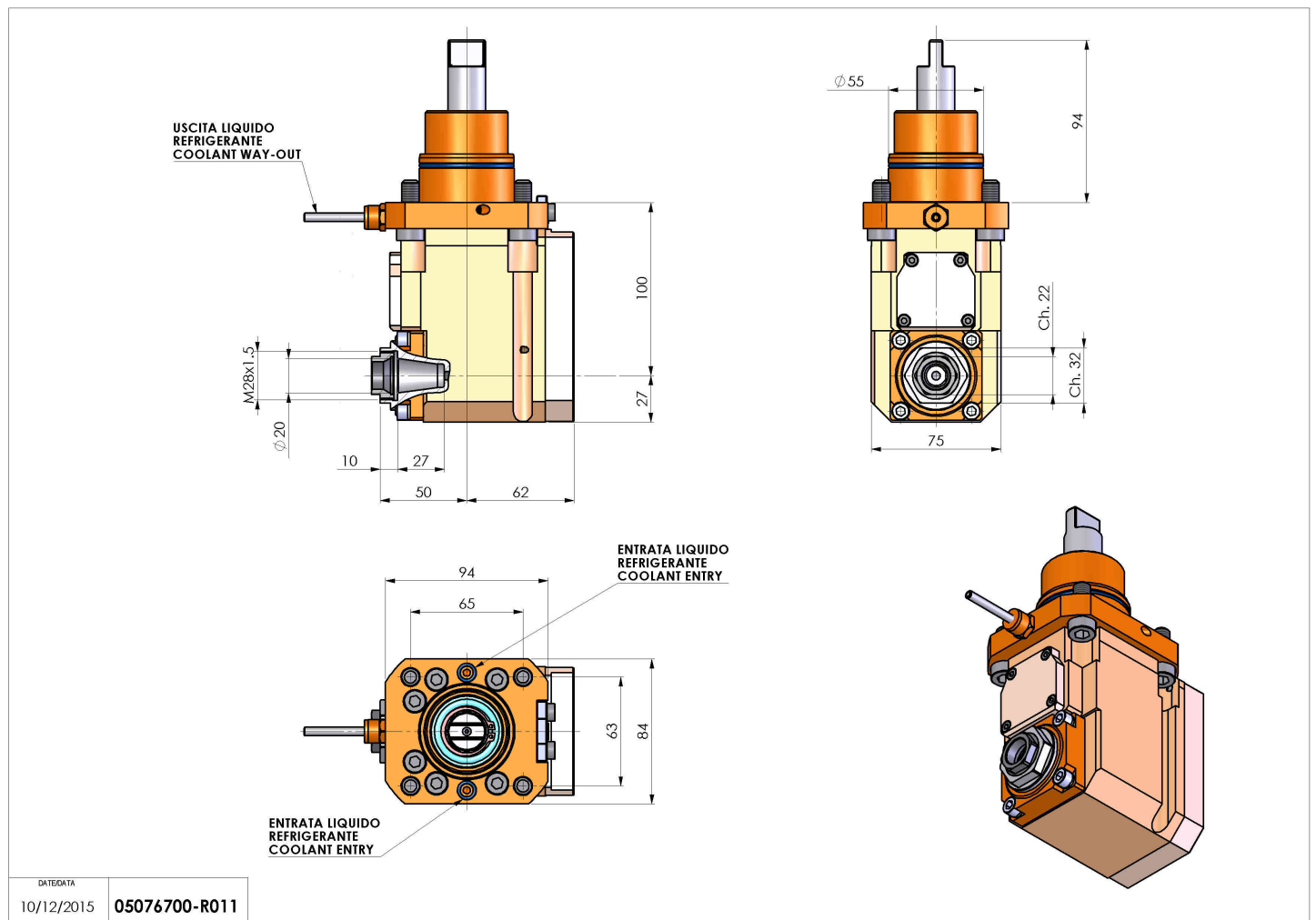

DATE/DATE	10/12/2015	05076700-R011
-----------	------------	---------------

Subject to technical changes